

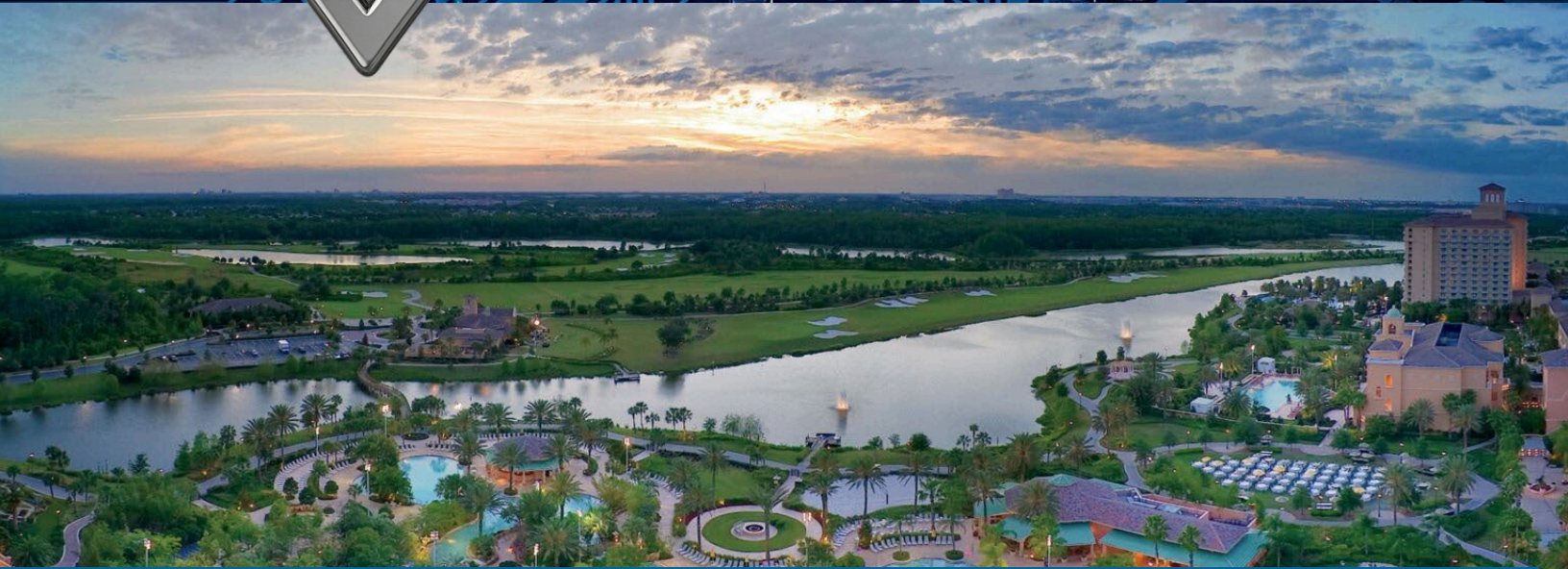

ITherm

ORLANDO, FL 2026

The 25th Intersociety Conference
on Thermal and Thermomechanical
Phenomena in Electronic Systems



JW Marriott Grande Lakes
Orlando, Florida, May 26 – 29, 2026

SPONSORS AND EXHIBITORS

PLATINUM SPONSORS



GOLD SPONSORS



SILVER SPONSORS



EXHIBITORS



TOUR SPONSORS



STUDENT DESIGN COMPETITION SPONSORS



Micro Nano Devices & Systems Lab



Semiconductor Packaging & Thermal Lab

(Multiscale Materials, Heat Transfer, Mechanics, and Reliability in Semiconductors)

WELCOME LETTER

On behalf of the organizing committee, we are delighted to welcome you to the **25th Intersociety Conference on Thermal and Thermomechanical Phenomena in Electronic Systems (ITherm 2026)**. ITherm is the leading international forum advancing the science and engineering of thermal, thermo-mechanical, and emerging technology challenges in electronic devices, packages, systems, and data centers. ITherm 2026 is co-located with the **76th Electronic Components and Technology Conference (ECTC)**, a premier venue for electronic packaging innovation.

ITherm 2026 delivers an expansive and forward-looking technical program featuring more than **220 presentations across five technical tracks**. Responding directly to the evolving needs of our field, we have introduced a new **Data Centers Track** with over 25 dedicated talks. Each morning opens with a keynote focused on critical challenges and opportunities: **Dr. Hart (IBM Research)** will explore quantum computing infrastructure; **Dr. Noveski (Micron)** will address the thermal challenges of HBM memory and AI systems; and **Prof. Swaminathan (Penn State)** will examine the future of 3D heterogeneous integration. We are also honored to host an invited presentation by **Dr. Samuel Graham (University of Maryland)**, the **2026 Richard Chu ITherm Award for Excellence** recipient. The program is further strengthened by five interactive scientific panel sessions and five Technology Talk sessions offering in-depth discussion of high-impact topics. Returning to ITherm is the **Art-in-Science Exhibition**, showcasing community-created artwork throughout the conference in the pre-function spaces. To mark this milestone year, a special luncheon retrospective on Thursday will celebrate 25 ITherm conferences since our founding in 1988.

ITherm continues its strong commitment to student engagement, featuring an interactive poster session with a record **70+ student presenters**, final presentations for the **2026 ASME/K-16 and IEEE/EPSS Student Design Competition**, and—by popular demand—a new **Student Mixer** on Wednesday evening to foster peer networking and community building.

We encourage attendees to fully engage with joint ITherm–ECTC activities. Events begin on Tuesday with **16 professional development courses, HIR Roadmap** (open to all) followed by a **Young Professionals Networking Panel**, creating expanded opportunities for learning and connection.

Exceptional sponsorship from industry, academia, and IEEE EPS grants enables student travel support, broadens participation, and enhances conference programming. We extend our sincere gratitude to all sponsors and exhibitors and encourage attendees to visit the exhibits and engage in meaningful technical exchange.

Thank you for being part of ITherm 2026. The conference's success reflects the strength of our community and the dedication of many volunteers. We gratefully acknowledge our track and session chairs, panel and technology talk organizers, special events organizers, reviewers, the Executive Committee, and all who contributed. A complete list of contributors appears later in this program.

Whether this is your first ITherm or you are a long-standing participant, we hope you feel energized by the technical depth and collaborative spirit of the conference.

ITherm 2027 will be held in **Denver, Colorado, USA, June 1–4, 2027**. We invite you to participate in the ITherm 2027 Program Planning Meeting (open to all) on Friday following the awards luncheon (2:00–3:00 pm). We thank this outstanding community and look forward to continuing the journey together.



Dr. Milnes P. David
General Chair



Prof. John (Jack) Maddox
Program Chair



Dr. Pritish Parida
Vice Program Chair



Prof. Sukwon Choi
Communications Chair



ACCÆLSIUS®

Two-phase, direct-to-chip liquid cooling
designed for the mission critical.



info@accelsius.com



www.accelsius.com



Discover Our
NeuCool Solutions

ADOPT WHAT'S NEEDED FOR MISSION CRITICAL COOLING





-  Delivers 4,500W per GPU socket, exceeding the limits of next-gen single-phase cold plates.
-  Designed with substantial thermal headroom, ensuring support for multiple chip generations.
-  Enables 35-44% savings in annual OpEx and 5-year TCO savings of 8-17% vs. single-phase.
-  Uses an eco-conscious dielectric refrigerant with an A1 safety rating, preventing leak-based damage to critical hardware.

TABLE OF CONTENTS

Sponsors and Exhibitors -----	Inside Front Cover	ITherm 25 th Anniversary Celebration-----	33
Welcome Letter -----	1	Art in Science Exhibition -----	33
General Information -----	4	Student Poster & Networking Session -----	36
Committee meetings -----	7	Last Year’s Best Posters (ITherm 2025) -----	37
ITherm Mobile App -----	7	ASME K-16 & IEEE/EPS Student Design Challenge -	40
Conference Organization Committee -----	10	Technology Talks -----	45
Conference Executive Committee -----	11	Panel Sessions -----	52
ITherm 2025 Best Paper Committee -----	13	Avram Bar-Cohen Best Paper Award Nominees ----	56
Last Year’s Best Papers (ITherm 2025)-----	14	Program: Tracks, Sessions and Presentations -----	60
Conference Keynotes-----	18	Paper Reviewers -----	90
2025 Richard Chu ITherm Award for Excellence ----	24	ITherm 2027 Call for Papers -----	94
Professional Development Courses-----	28	Hotel Map -----	96
Heterogeneous Integration Roadmap -----	29	Conference Map -----	Inside Rear Cover
Young Professionals Networking Panel-----	29	Program Overview -----	Outside Rear Cover
ITherm Student Mixer-----	29		

CONFERENCE DESCRIPTION & SUMMARY

Sponsored by the IEEE’s Electronics Packaging Society (EPS), ITherm 2026 is the leading international conference for the scientific and engineering exploration of thermal, thermomechanical and emerging technology issues associated with electronic devices, packages and systems.

- **220+ Technical Papers and Presentations** organized across five Technical Tracks: Component-Level Thermal Management (CT), System-Level Thermal Management (ST), Mechanics & Reliability (MR), Emerging Technologies & Fundamentals (EF), and Data Centers (DC)
- **3 Keynote Talks** on the Thermal challenges in HBM Memory and AI systems, Frontiers of Quantum Computing Infrastructure and the Future of 3D Heterogenous Integration
- **Richard Chu ITherm Award and Seminar** by **Prof. Samuel Graham**, Dean, Clark School of Engineering, University of Maryland
- **5 Technology Talks** providing deep dive talks on high-profile topics
- **5 Panels** discussing the latest industry challenges and trends
- **70+ Student Posters** showcasing the latest research in an interactive networking environment
- **Art-in-Science Exhibition** showcasing the creativity of the community at the intersection of art and science
- **ASME/K16 & IEEE/EPS Student Design Challenge Presentations**
- **ITherm Student Mixer Event**
- **25th Anniversary Celebration and Retrospective**
- **ECTC/ITherm Young Professional Networking Event**
- **16 Professional Development Courses** (requires registration through ECTC)



GENERAL INFORMATION

REGISTRATION

Web Registration Link:

<https://www.ieee-itherm.net/itherm-2026-registration/>.

On-Site Registration Location:

Lower level, Del Lago-Amarante Pre-Function

On-Site Registration Hours:

Tuesday, May 26: 1:00 PM – 5:00 PM
 Wednesday, May 27: 6:30 AM – 5:00 PM
 Thursday, May 28: 7:00 AM – 5:00 PM
 Friday, May 29: 7:00 AM – 12:00 PM

Conference Registration Includes:

- Admission to All Conference Sessions and the ITherm Exhibit Hall
- Breakfast and Luncheons (Wednesday, Thursday, and Friday)
- Digital Conference Proceedings
- Access to select events at ECTC: the Young Professionals Networking Event, EPS President’s Panel

Fees (Onsite Registration)	IEEE Member	Non-Member
ITherm Registration	\$950	\$1100
Student	\$500	\$500
IEEE Life Member	\$460	
Joint ITherm/ECTC Registration	\$1750	\$2100
One-Day Registration (Wed/Thu)	\$760	\$880
One-Day Registration (Fri)	\$570	\$660

CONFERENCE POLICIES

Cancellation Policy: All refund/cancellation requests must be provided in writing and received by May 19, 2026. There will be an administrative fee of US\$50 deducted from each refund.

Substitution Policy: All requests to substitute another person on an existing registration must be submitted in writing to the following email address support@ieee-itherm.net no later than May 19, 2026. There will be an administrative fee of US\$50 for each substitution.

Recording and Photography Policy: Attendees, including presenting authors, are strictly prohibited from photographing, recording or streaming presentations in any form (audio, video, still photography, etc.) without permission from ITherm. You are encouraged to follow up with presenters in between sessions to discuss their work or request additional information. Attendees are encouraged to capture memories of casual meeting activities with the permission of those being prominently photographed.

Photography Disclaimer: ITherm organizers frequently capture images, audio, and video of the event for archival and marketing purposes. By registering, you grant ITherm and its agents permission to use these media in marketing and promotional materials.

Copyright: The content presented in the ITherm proceedings is copyrighted by IEEE and for registered attendees only. By registering, you agree not to share content on platforms where non-registered attendees may access it.

Conduct Policy: IEEE has no tolerance for discrimination, harassment, or bullying in any form at IEEE-related events. All participants have the right to pursue shared interests without harassment or discrimination in an environment that supports diversity and inclusion. Participants are expected to adhere to these principles and respect the rights of others.

Age Policy: Any attendee under the age of 18 must be accompanied by an adult.

GENERAL EMERGENCY INFORMATION

Lost & Found

Safety & Security also handles all lost and found items. If an item is lost or left behind, please contact the Safety & Security Office at (407) 393-4153 or submit an inquiry at the link below. The hotel will be happy to assist you in locating and arranging the return of your items.

<https://forgotmyitem.com/Hotel/10061>

Fire & Evacuation

If a condition occurs to activate the fire alarm, a message will sound, accompanied by strobes, indicating that the hotel's emergency response team is investigating the cause of the alarm.

In the event of an ACTUAL FIRE EMERGENCY: A different message, with intermittent sirens, will sound and instruct all in the hotel to evacuate. All guests should evacuate to the nearest exit where they will be directed to the designated Assembly Area for an assessment of needs and a head count.

In the event that NO EMERGENCY condition exists: A message will sound indicating that the cause of the alarm has been investigated and that there is no need for evacuation.

Medical

- Call 9-1-1 for primary emergency calls with imminent or known danger/health
- If you come across a situation while on property you can dial extension "88" from any house phone located throughout our public spaces to get connected to the Safety & Security line, which is operated 24/7.
- If the emergency calls for medical assistance, a CPR/AED/First Aid trained member from the hotel team will be alerted and respond with a medical bag to assist

Key Contacts

Safety & Security Office

(407) 393-4357
(Available 24 Hours, 7 Days a Week)

Safety & Security Manager on Duty

(321) 354-5995

Safety & Security Emergency Line

Dial 88
(From any house phone)

Orange County Sheriff's Office

Dial 911 for Emergencies
Tel. 407-836-4357 for Non-Emergency
(Open 24 Hours, 7 Days a Week)

The Medical Concierge

www.themedicalconcierge.com
Tel. (407) 648-5252
(Open 24 Hours, 7 Days a Week)

Buena Vista Urgent Care

8216 World Center Dr., Orlando, FL 32821
(407) 465-1110
(Open 24 Hours, 7 Days a Week)

Walgreen's Pharmacy

10801 S John Young Parkway Orlando, FL 32837
Tel. (407) 251-7565
(Open 24 Hours, 7 Days a Week)

Hunters Creek ER

12100 John Young Parkway, Orlando, FL 32837
Tel. (407) 903-7033
(Open 24 Hours, 7 Days a Week)

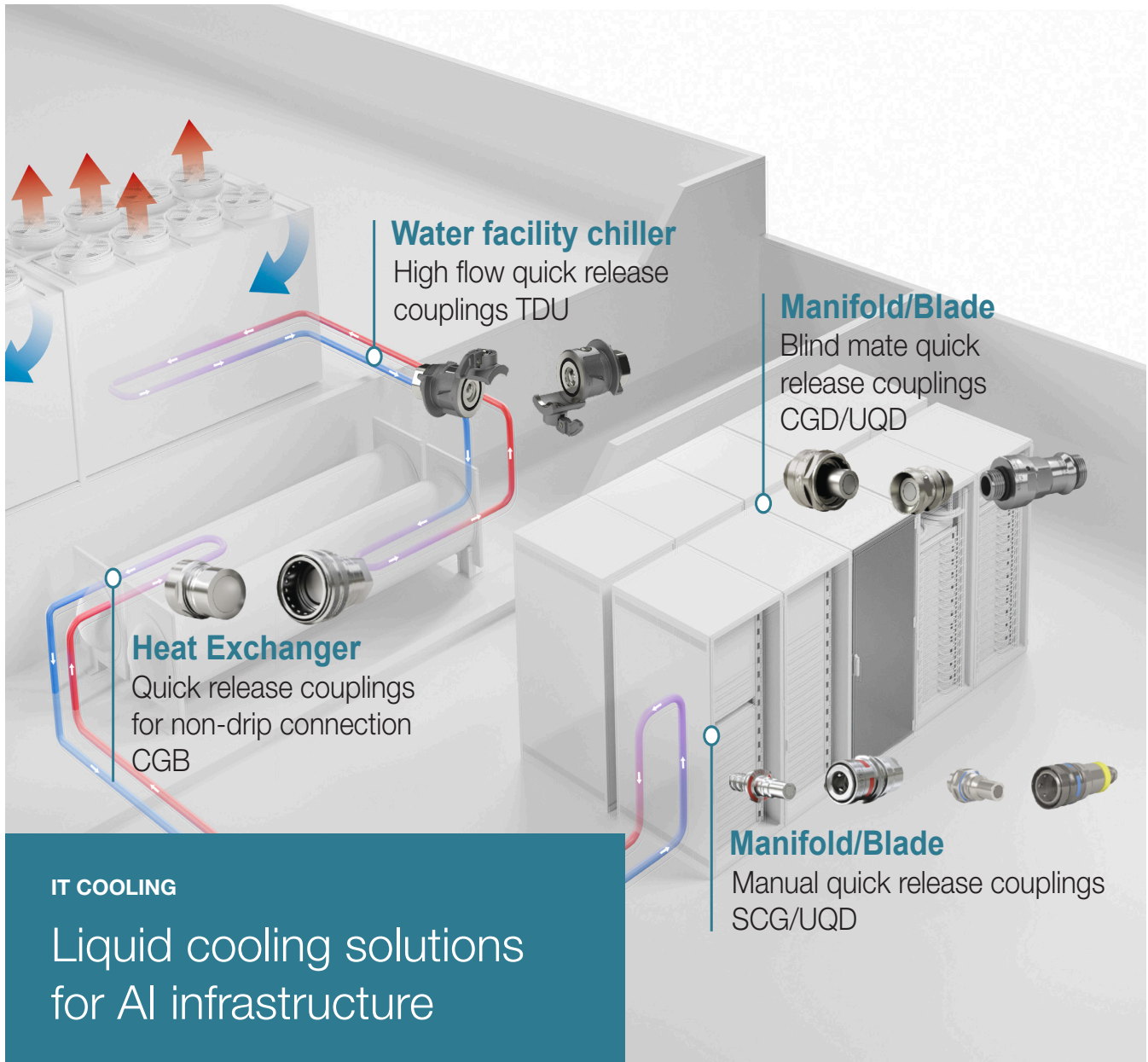

IT COOLING

Liquid cooling solutions for AI infrastructure

Future-forward connectors

Advanced quick disconnect technology delivering high-performance, secure connections, and efficient thermal transfer for next-generation AI infrastructure requiring reliability, consistency, and scalable system integration. As data centers continue to grow, we continue to innovate. Learn more about our newest liquid cooling innovations today by scanning the QR Code.

Stäubli – Experts in Man and Machine

www.staubli.com



COMMITTEE MEETINGS

ASME K-16 COMMITTEE AND JOURNAL OF ELECTRONIC PACKAGING (OPEN TO ALL)

Wednesday, May 27, 7:00 to 8:00 PM.
Lower level, Segura 6

IEEE EPS THERMAL MECHANICAL TECHNICAL COMMITTEE (OPEN TO ALL)

Thursday, May 28, 7:00 to 8:00 AM
Lower level, Cordova 2

ITHERM 2027 PROGRAM PLANNING (OPEN TO ALL)

Friday, May 29, 2:00 to 3:00 PM.
Lower level, Amarante 2-3

ITHERM EXECUTIVE COMMITTEE (BY INVITATION ONLY)

Thursday, May 28, 7:00 to 7:30 PM.
Lower level, Amarante 1

ITHERM CONFERENCE APP

Instructions for installing the ITherm 2026 Mobile App are available at:

[ieee-itherm.net/2026-conf-info](https://www.ieee-itherm.net/2026-conf-info).



CONNECT WITH ITHERM

- ITherm Website: <https://www.ieee-itherm.net/>
- Join the [ITherm LinkedIn Group](#) and follow [ITherm](#) on LinkedIn: /company/ieee-itherm
- Tag [ITherm](#) in your LinkedIn Posts using **@IEEE-ITherm** and **#ITherm2026**
- Follow ITherm on [X](#) | [@IEEE_ITherm](#)
- Follow ITherm stories on [Medium.com](#)



START COOLING SMARTER.

**QUICK DISCONNECT COUPLINGS FOR
AI DATA CENTERS AND
HIGH-PERFORMANCE COMPUTERS**

cpcworldwide.com/Cool



WANT TO COLLABORATE?

For designers of AI data centers and high-performance computers, we've curated tools and resources to help you tackle any challenge:

- **ASK AN ENGINEER**
- **LIQUID COOLING TECH GUIDES**
- **WHITE PAPERS**
- **CAD FILES**

Visit us at cpcworldwide.com/Cool to get started.



CONFERENCE ORGANIZATION COMMITTEE

ORGANIZATION COMMITTEE

General Chair	Milnes P. David	IBM Corporation
Program Chair	John (Jack) Maddox	University of Kentucky
Vice Program Chair	Pritish Parida	IBM Research
Communications Chair	Sukwon Choi	Penn State

COMPONENT-LEVEL THERMAL MANAGEMENT TRACK (CT)

Chair	Stephanie Allard	IBM Corporation
Co-Chair	Luca Amalfi	Seguente Inc.
Co-Chair	Darin Sharar	TauMat
Co-Chair	Yuanchen Hu	Lightmatter
Co-Chair	P. Subrahmanyam	Dell

SYSTEM-LEVEL THERMAL MANAGEMENT TRACK (ST)

Chair	Amir H. Shooshtari	University of Maryland
Co-Chair	Shadi Mahjoob	California State University
Co-Chair	Christina Seeholzer	HRL

EMERGING TECHNOLOGIES & FUNDAMENTALS TRACK (EF)

Chair	Lang Yuan	Oracle
Co-Chair	Patrick Shamberger	Texas A&M University
Co-Chair	Tiwei Wei	University of California
Co-Chair	Rachel McAfee	US Army Research Labs & UMD

MECHANICS & RELIABILITY TRACK (MR)

Chair	David Huitink	University of Arkansas
Co-Chair	Paul Paret	NLR
Co-Chair	Morgan Roddy	University of Arkansas

DATA CENTERS THERMALS TRACK (DC)

Chair	Baris Dogruoz	Microsoft
Co-Chair	Peter de Bock	Eaton
Co-Chair	Jimil Shah	MARA Holdings

SPECIAL TECHNICAL CONTRIBUTIONS

Panels Chair	Victor Chiriac	Global Technology Cooling Group
Technology-Talk Chair	Georges Pavlidis	University of Connecticut
Technology-Talk Co-Chair	Qian Han	Luxshare
Research Workshop Chair	Patrick Shamberger	Texas A&M University
Research Workshop Co-Chair	Sreekant Narumanchi	NLR
Research Workshop Co-Chair	Satish Kumar	Georgia Institute of Technology
Poster Session Co-Chair	Kalind Baraya	IBM Corporation
Poster Session Co-Chair	Aakrati Jain	IBM Research
Keynote Chair	Justin Weibel	Purdue University
Keynote Co-Chair	Vadim Gektin	Qualcomm
Art-in-Science Exhibition Chair	Pranay Nagrani	IBM Corporation
Art-in-Science Exhibition Chair	Amir H. Shooshtari	University of Maryland
Student Mixer Chair	Felipe Valenzuela-Gaete	IBM Corporation
PDC Short Course Chair	Jeffrey Suhling	Auburn University
PDC Short Course Co-Chair	Kitty Pearsall	IBM (Retired)

EPS/K16 Student Design Chair	Amy Marconnet	Purdue University
EPS/K16 Student Design Co-Chair	Tiwei Wei	UCLA

ADMINISTRATIVE

Sponsoring & Exhibitor Chair	Mehdi Asheghi	Stanford University
Finance Chair	Gargi Kailkhura	Arista
Finance Co-Chair	Sameer Rao	University of Utah
Operations Chair	Yuanchen Hu	Light Matter
Operations Co-Chair	Pardeep Shahi	Nvidia

COMMUNICATION

Conference Proceedings Manager	Paul Wesling	ITherm
Technical Program and Design	John (Jack) Maddox	University of Kentucky
Technical Program and Design	Pritish Parida	IBM Research
Branding and Graphic Design	John (Jack) Maddox	University of Kentucky
Branding and Graphic Design	Milnes P. David	IBM Corporation

AWARD COMMITTEE

Richard Chu ITherm Award Chair	Sushil Bhavnani	Auburn University
Richard Chu ITherm Award Co-Chair	Koneru Ramakrishna	Thermal Consultant
Richard Chu ITherm Award Co-Chair	Yogendra K. Joshi	Georgia Institute of Technology
Best Paper Award Chair	Yogendra K. Joshi	Georgia Institute of Technology
Best Paper Award Co-Chair	Koneru Ramakrishna	Thermal Consultant
Best Paper Award Co-Chair	Jeffrey Suhling	Auburn University

INTERNATIONAL IThERM AMBASSADORS

Ambassador (Canada)	Roger Kempers	York University
Ambassador (China)	Liang Chen	
Ambassador (Japan)	Fushinobu Kazuyoshi	Tokyo Institute of Technology
Ambassador (Ireland)	Tim Persoons	Trinity College Dublin
Ambassador (India)	Rishi Raj	IIT Patna
Ambassador (Middle East)	Abdul Rouf Baba	Technology Innovation Institute
Ambassador (Singapore)	Poh Seng Lee	National University of Singapore

CONFERENCE EXECUTIVE COMMITTEE

The Executive Committee is composed of prior General Chairs who continue to participate and advise the conference leadership and provide continuity.

Dereje Agonafer	UT Arlington	Satish Kumar	Georgia Tech
Cristina H. Amon	University of Toronto	Tom Lee	Xilinx
Mehdi Asheghi	Stanford University	Amy Marconnet	Purdue University
Sushil H. Bhavnani	Auburn University	Michael Ohadi	UMD / Flexnode
Thomas Brunschweiler	IBM Research	Alfonso Ortega	Villanova University
Dustin Demetriou	IBM Corporation	Koneru Ramakrishna	Thermal Consultant
Vadim Gektin	Qualcomm	Bahgat Sammakia	SUNY Binghamton
Ashish Gupta	AMD	Jeffrey Suhling	Auburn University
Madhusudan Iyengar	Google	Sandeep Tonapi	Anveshak
Yogendra K. Joshi	Georgia Tech	Justin Weibel	Purdue University
Gary B. Kromann	Thermal Consultant		

Supercharge liquid cooling performance with Corintis

Discover how our platform can help you with **designing, building, testing and mass-producing** leading-edge liquid cooling for high-power chips in data centers, to bring better products to the market, faster.

1.0 DESIGN

Optimal cooling tailored to your microchip with Glacierware

Glacierware is a CFD simulation platform dedicated to micro-scale liquid cooling design, automatically guiding you to the most efficient solution for your chip. Explore a wide range of thermal scenarios and simulate them all in one streamlined platform. One powerful tool for designing, testing, and optimizing your liquid cooling solutions.

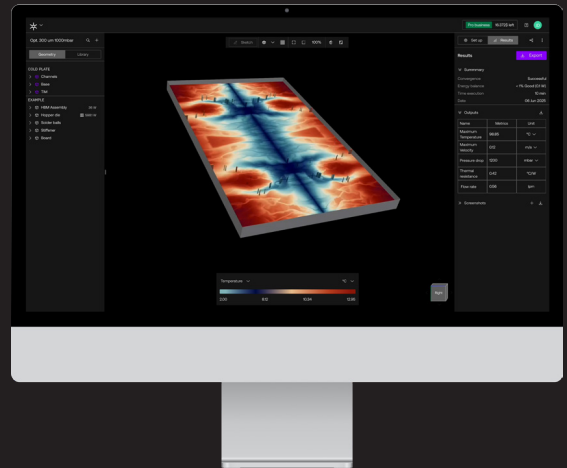

2.0 BUILD

Precision cooling, beyond skiving

Integrates cooling directly into the package, achieving up to 10x higher die-level heat fluxes and eliminating the need for thermal interface materials. Prototyping and manufacturing services of copper cold plates or in-silicon cooling, beyond the constraints of skiving.



ITherm 2026 BEST PAPER AWARD COMMITTEE

Committee Chairs:

Prof. Yogendra K. Joshi (Georgia Institute of Technology),
Dr. Koneru Ramakrishna
Prof. Jeffrey Suhling (Auburn University)

Committee:

Prof. Damena Agonafer	University of Maryland	Dr. Przemyslaw Jakub Gromala	Robert Bosch GmbH, Germany
Dr. Luca Amalfi	SEGUENTE	Dr. Yuanchen Hu	Lightmatter
Prof. Mehmet Arik	Auburn University	Prof. Yogendra K. Joshi (Chair)	Georgia Institute of Technology
Dr. Lavanya Aryasomayajula	ON Semiconductor	Dr. Rajiv K. Mongia	Intel Corporation
Prof. Mehdi Asheghi	Stanford University	Prof. Tim Persoons	Trinity College, Dublin, Ireland
Dr. Stephanie Allard,	IBM Corporation	Prof. Mark D. Poliks	Binghamton University, USA
Prof. Cemal J. Basaran	University at Buffalo	Dr. Koneru Ramakrishna (Co-Chair)	Thermal Consultant
Prof. Sushil H. Bhavnani	Auburn University	Dr. Srikanth Rangarajan	Binghamton University
Prof. Kuo-Ning Chiang	National Tsing Hua University, Taiwan	Prof. Bahgat G. Sammakia	Binghamton University
Dr. Victor A. Chiriac	Global Cooling Technology Group	Prof. Patrick J. Shamberger	Texas A & M University
Dr. Peter De Bock	Eaton Corporation	Prof. Amir H. Shooshtari	University of Maryland
Dr. M. Baris Dogruoz	Microsoft Corporation	Dr. Prabhakar Subrahmanyam	Dell Technologies Inc.
Prof. Yogesh Fulpagare	University of Texas at Arlington	Prof. Jeffrey C. Suhling (Co-Chair)	Auburn University
Dr. Reza Ghaffarian	Jet Propulsion Laboratories, NASA	Prof. Ronald Warzoha	US Naval Academy

ITHERM 2025 PAPER AWARDS

COMPONENT-LEVEL THERMAL MANAGEMENT TRACK

PROF. AVRAM BAR-COHEN BEST PAPER

PHASOR-BASED DEHOMOGENISATION FOR MICROCHANNEL COOLING TOPOLOGY OPTIMISATION

Hao Li, Peter Dørffler Ladegaard Jensen, Rebekka Vaarum Woldseth, Joe Alexandersen

DOI: [10.1109/ITHERM55376.2025.11235758](https://doi.org/10.1109/ITHERM55376.2025.11235758)

RUNNER UP	RUNNER UP	RUNNER UP
EXPERIMENTAL CHARACTERIZATION OF A LOW THERMAL RESISTANCE MICROCHANNEL EVAPORATOR UTILIZING LOW GWP REFRIGERANT FOR HIGH POWER GPU APPLICATIONS	DIRECT VISUALIZATION OF LOCAL THERMAL CONDUCTIVITY AND BOUNDARY CONDUCTANCE OF DIAMOND PARTICLES	DEVELOPMENT OF LIQUID METAL AND SILICON PIN FIN COMPOSITE THERMAL INTERFACE MATERIALS
David J. Apigo, Sarwesh N. Parbat, Haotian Jia, Haoyun Qiu, Pouya Abirzadeh, Manohar Bongarala, Syed Faisal, Rishav Roy, Nenad Miljkovic & Todd Salamon	Luke Gyubin Min, Heungdong Kwon, Christopher Perez, Mehdi Asheghi & Kenneth E. Goodson	Matthew Coughlin, Andrew Clements, Fangzhou Wang, Luke Gyubin Min, Kaiying Jiang, Heungdong Kwon, Mehdi Asheghi & Kenneth Goodson
DOI: 10.1109/ITherm55376.2025.11235727	DOI: 10.1109/ITherm55376.2025.11235652	DOI: 10.1109/ITherm55376.2025.11235805

SYSTEM-LEVEL THERMAL MANAGEMENT TRACK

PROF. AVRAM BAR-COHEN BEST PAPER

COMPARISON OF 3D MANIFOLD ARCHITECTURES FOR COOLING OF INTERNAL HEATSINKS USING EXTERNAL AIRFLOW

G. Farrell, R. Nimmagadda, S. N. Joshi, D. J. Lohan, E. M. Dede, T. Persoons

DOI: [10.1109/ITherm55376.2025.11235714](https://doi.org/10.1109/ITherm55376.2025.11235714)

RUNNER UP	RUNNER UP
AUTOMATED ELECTRO-THERMAL MODELING FRAMEWORK OF DISTRIBUTED VERTICAL POWER DELIVERY ARCHITECTURES WITH SUBSTRATE-EMBEDDED MICROFLUIDIC COOLING	RESILIENCY OF LIQUID-TO-LIQUID COOLING SYSTEMS IN DATA CENTERS UNDER FAILURE SCENARIOS
Mingeun Choi, Sriharini Krishnakumar, Yaroslav Popryho, Ramin Rahimzadeh Khorasani, Madhavan Swaminathan, Inna Partin-Vaisband and Satish Kumar	Ali Heydari, Himanshu Modi, Pardeep Shahi, Lochan Sai Reddy Chintaparthi, Anto Barigala, Mohammad Raisul Islam, Dereje Agonafer, Mohammad Tradat, Saket Karajgikar, Jeremy Rodriguez
DOI: 10.1109/ITherm55376.2025.11235621	DOI: 10.1109/ITherm55376.2025.11235581

MECHANICS AND RELIABILITY TRACK

PROF. AVRAM BAR-COHEN BEST PAPER

IMPACT OF NON-FLAT HEAT SINK SURFACE ON DEGRADATION OF THERMAL GREASES

Ritwik V. Kulkarni, Nolan P. Gronowski, Pranay P. Nagrani, Amy M. Marconnet

DOI: [10.1109/ITherm55376.2025.11235649](https://doi.org/10.1109/ITherm55376.2025.11235649)

RUNNER UP

DEVELOPMENT OF A REDUCED-ORDER NODAL RELIABILITY FRAMEWORK FOR DATA CENTER APPLICATIONS

Tyler Schostek, Nirmal Rai, Kimberly Saviers, Davide Ziviani

DOI: [10.1109/ITherm55376.2025.11235775](https://doi.org/10.1109/ITherm55376.2025.11235775)

EMERGING TECHNOLOGIES AND FUNDAMENTALS TRACK

PROF. AVRAM BAR-COHEN BEST PAPER

THERMAL IMAGING AND FLOW VISUALIZATION OF CAPILLARY-DRIVEN TWO-PHASE BOILING IN SILICON MICROCHANNELS COATED WITH POROUS COPPER WICK

Yujui Lin, Heungdong Kwon, Kewei Xiao, Man Prakash Gupta, Michael Degner, Mehdi Asheghi, H. Alan Mantooth & Kenneth E. Goodson

DOI: [10.1109/ITherm55376.2025.11235797](https://doi.org/10.1109/ITherm55376.2025.11235797)

RUNNER UP

CONCEPT DESIGN OF A CONFINED DIRECT TWO-PHASE JET IMPINGEMENT COOLER WITH PHASE SEPARATION OF LOW-SURFACE-TENSION FLUIDS

Gopinath Sahu, Ketan Yogi, Tiwei Wei, Justin Weibel

DOI: [10.1109/ITherm55376.2025.11235679](https://doi.org/10.1109/ITherm55376.2025.11235679)

RUNNER UP

FABRICATION AND EXPERIMENTAL EVALUATION OF BENDABLE COPPER FLAT-PLATE OSCILLATING HEAT PIPES

Ishan Tandon, Qian Qian, Zekun Wu, Ahmad Rosmahidi, Justin A. Weibel, Liang Pan

DOI: [10.1109/ITherm55376.2025.11235810](https://doi.org/10.1109/ITherm55376.2025.11235810)



Precision Thermal Characterization for AI Hardware & Heterogeneous Integration

Submicron Resolution | Ultrafast Response | Non-Destructive Testing

Unlock the power of advanced optical thermal characterization with Microsanj.

Our industry-leading solutions empower researchers to solve the toughest thermal and thermomechanical challenges in 2.5D/3D-IC, AI chiplets, and photonics—bridging the gap between simulation and reliability.

Our Technology Portfolio

- **SanjSCOPE™**: Submicron, picosecond transient thermal imaging for GaN, SiC, and Silicon Photonics.
- **irSCOPE™**: Infrared lock-in imaging for PCB and open circuit analysis.
- **IMAG SANJ™**: High-resolution wafer-level thermal testing.
- **TDTR**: Time-domain thermoreflectance for bulk, thin film, and interface analysis.
- **OPP**: 2D surface mapping for 3DICs, GaN, GaAs, Si, and defect detection.
- **emVIEW™**: Over-the-air electromagnetic near-field imaging for antenna and EM applications.

Why Microsanj?

- **250nm Spatial Resolution**: Pinpoint submicron hot spots in advanced materials
- **500 Picosecond Response**: Capture nanosecond-scale thermal events
- **Seamless Integration**: Works with RF, semiconductor, and photonics testing
- **Non-Destructive Analysis**: Precise insights without altering your device
- **Advanced Reliability Validation**: Identify delamination and thermal stress points in stacked-die architectures
- **Submicron Heat Mapping**: Pinpoint hot spots in high-power-density AI processors and wide bandgap devices
- **Expert Support**: Decades of proven results, trusted by industry leaders

Applications

- Semiconductor device analysis
- Advanced packaging & stacked die
- Silicon photonics
- GaN & other wide bandgap devices
- RF/microwave circuits
- Embedded antenna arrays
- Multi-layer thermal analysis, TBR, TSVs, Interposers, etc.



Transient Thermal Imaging of 0.25µm GaN HEMT

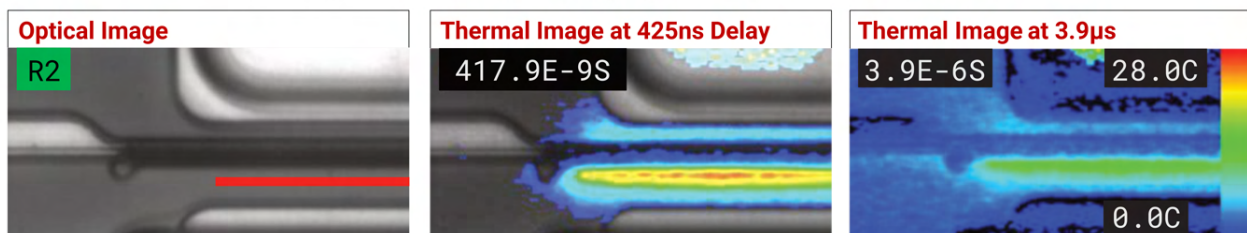

Microsanj
The Future of Thermal Imaging

www.microsanj.com | info@microsanj.com





Optical Sampling for Heat-Transport Analysis with Time-Domain Thermoreflectance

Submicron Resolution | Ultrafast Response | Non-Destructive Testing

Microsanj's dual-laser heterodyne platform delivers nanosecond and picosecond-resolution thermal conductivity and diffusivity measurements — covering 10nm thin films through to package-level structures.

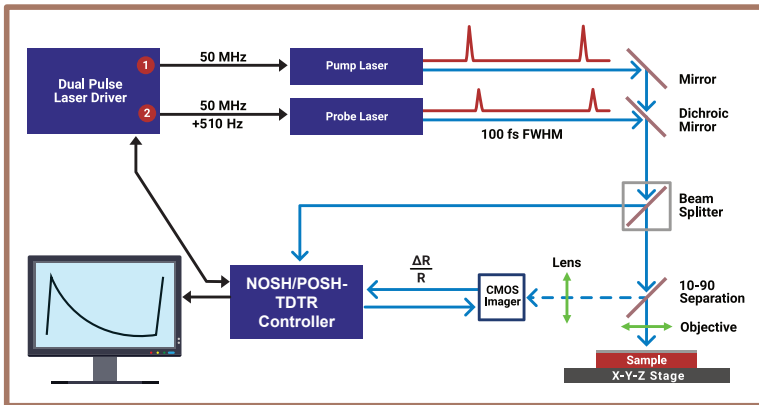

Dual femtosecond lasers with probe offset frequency enables rapid, high-resolution measurements without mechanical delay lines. The high-precision stage enables easy sample adjustment in all three spatial dimensions.

Features

- **Covers the full range** — 10nm thin films to package-level thermal characterization in a single platform family
- **NOSH-TDTR™** Nanosecond Single-point materials, films, and structural analysis
- **POSH-TDTR™** Picosecond Single-point materials and thin-film analysis
- **TDTR:** Time-domain thermoreflectance for bulk, thin film, and interface analysis.
- **Supports** Si, SiC, GaAs, GaN, diamond, ceramics and other heterogeneous packaging materials
- **Powered by SanjTHERM™** software for automated acquisition and thermal property identification

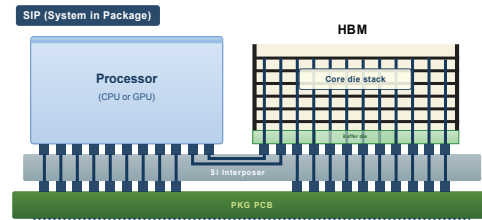
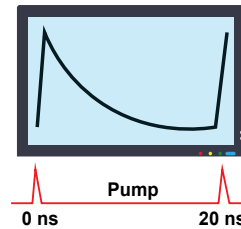
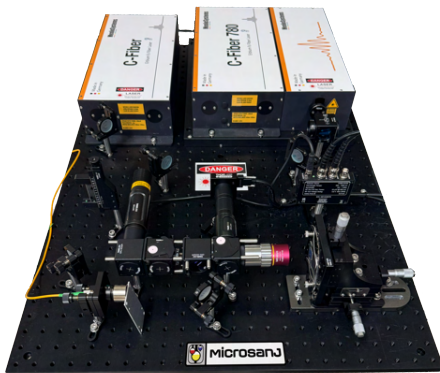

Microsanj - Accelerating iTherm Innovation through Advanced Thermal Characterization



Microsanj
The Future of Thermal Imaging

www.microsanj.com | info@microsanj.com



KEYNOTES

Chairs: Justin Weibel (Purdue University) and Vadim Gektin (Qualcomm)

SPONSORED BY



K-1: FRONTIERS OF QUANTUM COMPUTING INFRASTRUCTURE

WEDNESDAY, MAY 27, 9:30 AM – 10:30 AM

TEXOMA



Dr. Sean Hart
Research Scientist - Quantum

IBM Research

Abstract: Continued advances in the scale, quality, and speed of commercial quantum computers have pushed such machines toward an era of quantum advantage, when quantum computers will deliver solutions to practical, real-world computational tasks. This talk will highlight IBM Quantum's leadership in this space, surveying our roadmap to error-corrected quantum computers based on superconducting qubits and the subsystem hardware enabling this scaling. With respect to hardware, we will provide a perspective on critical areas for components and infrastructure development in support of this vision.

Bio: Sean Hart is a research scientist at IBM Quantum, leading signal delivery development for large-scale quantum computers. Prior to joining IBM, Sean performed postdoctoral studies at Stanford University and obtained a PhD in experimental physics at Harvard University.

K-2: THERMAL CHALLENGES IN HBM MEMORY PACKAGE AND AI SYSTEMS

THURSDAY, MAY 28, 9:30 AM – 10:30 AM

TEXOMA



Dr. Vladimir Noveski

Director Advanced Memory Architecture
Modeling and Simulations

Micron Technology Inc.

Abstract: Advanced 2.5D and 3D-integrated memory systems face thermal limitations due to high power density at the HBM memory stack's base and extended heat removal paths through layers with varying thermal resistance. Even with improved cooling, three challenges persist: (1) memory devices have lower thermal tolerance than logic; (2) the bottom logic die suffers from a highly resistive thermal path; and (3) localized hot spots risk device and data integrity.

This review paper will focus on the HBM thermal enhancements by package or DRAM silicon architecture change, and the key materials in the silicon and the package of the HBM product, and will also discuss the system level GPU/NPU/TPU environments and SIP level (COWOS) cooling solution roadmaps in both 2.5D and 3D system level solutions.

The architecture driven Thermal improvement solutions are: 1) Thermal bumps and Thermal vias on DRAM and Base die, 2) Hybrid bonding (die to die in the stack) as improvement to solder based Thermal Compression Bonding (TCB), 3) Thermally conductive (TC) spacer / heat spreader integrated in the HBM package, 4) Logic die on the top of the stack, 5) integrate the HBM with new SIP level cooling solutions on the roadmap such as immersion cooling, two phase cooling and microfluidics.

In addition to architectural changes mentioned above, Micron will also discuss the new Technology Development trend in evaluating new thermally conductive dielectrics i.e. a low-CTE, high-modulus, high-thermal-conductivity dielectric materials such as aluminum nitride (AlN), diamond, and boron nitride (BN), which offer superior thermal transmission while maintaining electrical insulation (wide bandgap). The application of these materials will be discussed from the Silicon FEOL, BEOL to HBM memory package perspective, but primarily will be applied as 1) interlayer dielectric as Al-O-N if possible to generate $K_e=2.9-3.1$ or less, 2) FS or BS Passivation layer, 3) Bonding layer for Hybrid bond, 4) gap fill material (replace MC).

Bio: Dr. Noveski holds a PhD in Chemical Engineering and 22+ years of professional experience in packaging and backend leadership roles in the semiconductor industry in leading US companies (Intel, QCOM, Apple, Micron). He currently manages the advanced memory TD team in Micron defining the package architecture, test chip and package design, and modeling and simulations for thermal and mechanical HBM package risks.



Waterless, Two-Phase Cooling Built for AI at Scale

Deployment-ready infrastructure delivering predictable, full-performance AI — without water, throttling, or power waste.

Proven in Factory Deployment

Powering a first-of-its-kind, waterless AI factory, proving two-phase cooling at true AI-scale. **76+ Global Developments**

Why ZutaCore

- ✓ Waterless, two-phase direct-to-chip cooling
- ✓ Eliminates thermal throttling at extreme power densities
- ✓ Factory-integrated and production-ready
- ✓ Designed for continuous, agentic, real-time AI workloads

Platform at Scale

ZUTACORE PLATFORM: BUILT FOR DEPLOYMENT

- ✓ Chip → rack → row → AI factory
- ✓ End-of-Row CDU family (1.2MW & 2MW)
- ✓ Two-Phase Sidecar (240kW racks)
- ✓ OmniTherm™ cold plates (next-gen silicon ready)

Channel Ecosystem

CERTIFIED. INTEGRATED. LISTED.

- ✓ NVIDIA HGX B300 Partner Cooling Solution
- ✓ NVIDIA Certified ASRock Rack systems
- ✓ Factory-integrated NVIDIA B300 servers
- ✓ AMD MI-series server integrations

PERFORMANCE VALIDATED WITH MUNTERS



Sustainability at Scale

BUILT FOR SCALE, ENGINEERED FOR SUSTAINABILITY—NO COMPROMISE REQUIRED.

- ✓ Waterless cooling to remove dependency on scarce resources
- ✓ End-of-Row CDU family (1.2MW & 2MW)
- ✓ Lower energy overhead through highly efficient thermal design
- ✓ Stable, high-density performance without throttling or over-provisioning

In Summary



Higher uptime and predictable SLA delivery



Full GPU performance - continuously, not in bursts



Lower cooling energy and power thrashing



Longer silicon lifespan at extreme densities

The Impact

Lower operational risk, higher usable compute per rack, and measurable reductions in cooling energy without water.

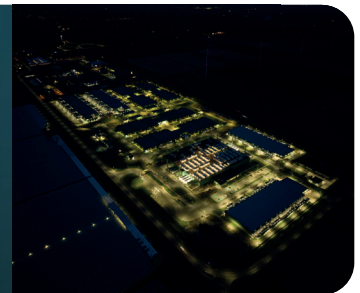

K-3: THE FUTURE OF 3D HETEROGENOUS INTEGRATION

FRIDAY, MAY 29, 9:30 AM – 10:30 AM

TEXOMA



Prof. Madhavan Swaminathan

Department Head of Electrical Engineering &
William E. Leonhard Endowed Chair

Director, Center for Heterogeneous Integration of Micro Electronic Systems

Pennsylvania State University

Abstract: Moore's law has helped us for 5+ decades through monolithic integration with packaging taking a back seat. We have now reached a stage in the semiconductor industry where 3D Heterogeneous Integration (3DHI) is taking front seat, with billions of dollars being invested in it. Does this mean the end of Moore's law? Why is 3DHI so critical for Artificial Intelligence (AI) to succeed? Can 3DHI be used to continue Moore's law? This talk will address several of these questions along with potential solutions and challenges in the context of emerging applications and systems.

Bio: Madhavan Swaminathan is the Department Head of Electrical Engineering and is the William E. Leonhard Endowed Chair at Penn State University. He also serves as the Director for the Center for Heterogeneous Integration of Micro Electronic Systems (CHIMES), an SRC JUMP 2.0 Center www.chimes.psu.edu.

Prior to joining Penn State, he was the John Pippin Chair in Microsystems Packaging & Electromagnetics in the School of Electrical and Computer Engineering (ECE), Professor in ECE with a joint appointment in the School of Materials Science and Engineering (MSE), and Director of the 3D Systems Packaging Research Center (PRC) – a graduated NSF-Engineering Research Center (ERC), Georgia Tech (GT). Prior to GT, he was with IBM working on packaging for supercomputers.

Prof. Swaminathan's interdisciplinary research on semiconductor packaging and systems integration over the years have resulted in 650+ technical publications, 200+ invited presentations (seminars, keynotes, panels), 3 books, 5 book chapters, 31 patents, 35 best paper and student paper awards, 5 GT awards, 2 start-ups, and several international recognitions with the recent one being the 2024 IEEE Rao R. Tummala Electronics Packaging Award (highest technical field award in packaging) for "contributions to semiconductor packaging and system integration technologies that improve the performance, efficiency, and capabilities of electronic systems". He is also the founder of the IEEE Conference on Electrical Design of Advanced Packaging and Systems (EDAPS), a premier conference sponsored by the IEEE Electronics Packaging Society (EPS). He is a Fellow of IEEE, Fellow of the National Academy of Inventors (NAI), Fellow of Asia-Pacific Artificial Intelligence Association (AAIA), and has served as the Distinguished Lecturer for the IEEE Electromagnetic Compatibility (EMC) society. He serves as an advisor to India Semiconductor Mission and on the external advisory board for Move2THz (an EU initiative), as well as advisor to 3DGS and Claros.

Discover the Innovation of Liquid Cooling Technology



IMMC's innovative design and technology make it a leader in high-performance, eco-friendly cooling solutions for modern data centers

Now, how well you cool your semiconductors determines how well they perform. Lowering the temperature allows the semi-conductor to work properly and even faster, without thermal throttling.

KoolMicro has developed **an Integrated Manifold MicroChannel (IMMC) technology to cool high-power-density semiconductors up to eight times more effective** than conventional cooling method.

IMMC's unique manifold microchannel structure, chip integration method, and flow control method enables uniform cooling of a larger area with lower pumping power at a reasonable price. We have key **patents and experienced engineers to provide customized thermal solutions** for high performance data centers, automotives, semiconductors, and advanced packages.

Top-Notch Cooling



Featuring a groundbreaking liquid cooling system, the IMMC provides superior cooling performance. This advanced technology ensures GPUs operate efficiently without overheating, supporting high performance for demanding tasks such as AI and Large Language Models (LLMs).

Compact Size

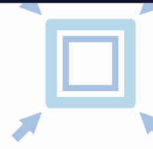

The IMMC's slim design saves space, allowing for more GPUs to fit in a server rack. Its compact size is ideal for crowded server rooms, optimizing the use of available space for advanced computing hardware.

Eco-Friendly



IMMC employs a closed-loop water cooling system that reduces carbon emissions and water consumption. This approach lowers CO₂ emissions by 50% compared to standard air-cooled systems and minimizes water use, making it an environmentally friendly choice for data centers.

A cutting-edge cooling solution that combines technological innovation and sustainability



Accelerated Compute

Achieves 25% faster computing speeds, enhancing overall processing efficiency



Energy Savings

IMMC consumes 15% less electricity for cooling 1,000W/cm²



Environmental Impact

IMMC decreases CO₂ output by 50%

Manifold-Microchannel Liquid Cooling Method

IMMC Coldplate for Module



IMMC Coldplate for Package



IMMC Coldplate for Multi Package

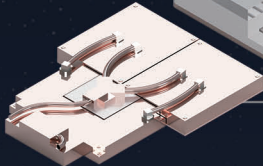

IMMC employs high thermal conductive copper microchannels and an intelligent fluid-distribution manifold to deliver exceptional cooling, achieving 1,000W/cm². This innovative system uses water for cooling, effectively managing hotspots and maintaining uniform temperatures across dense server regions. It reduces CO₂ emissions by 50% compared to standard air cooling, benefiting the environment and conserving energy.

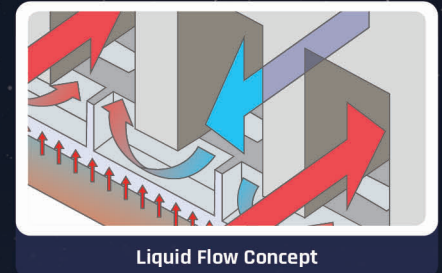
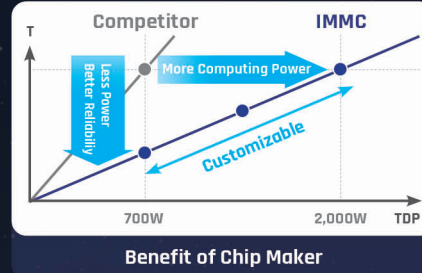

Product launches from IMMC-1 to IMMC-3



Optimal location for supplying semiconductor cooling solutions

Conducting R&D, and mass production primarily in technologically advanced domestic centers, planning to establish sales and specialized assembly hubs based in the U.S.



Address

- **Headquarter (Daejeon)**
2nd Floor, 99 Daehak-ro, Yuseong-gu, Daejeon, South Korea [34134]
- **R&D Center (Dongtan)**
2624, 27 Dongtancheomdansaneop 1-ro, Dongtan-gu, Hwaseong-si, Gyeonggi-do, South Korea [18469]
- **KoolMicro Silicon Valley Customer Center (US, San Jose)**
#308, 3003 North 1st Street, San Jose CA, United States [95134]
- **KoolMicro Advanced R&D Center (US, Atlanta)**

Contact Us

- **E-mail** info@koolmicro.com



RICHARD CHU ITherm AWARD FOR EXCELLENCE

**MATERIALS, PROCESS, AND METROLOGY: INNOVATING THERMAL
MANAGEMENT SOLUTIONS AT THE DIE LEVEL**

AWARD LUNCHEON TALK

WEDNESDAY, MAY 27, 1:00 PM – 2:00 PM

LOBBY LEVEL, PALAZZO EFGH



2026 Richard Chu ITherm Awardee

Prof. Samuel Graham

Dean, Clark School of Engineering
University of Maryland

Abstract: Wide bandgap (WBG) electronics are critical to the development of future power, RF, and optoelectronics and have become ubiquitous in our everyday lives. The growth of materials based on gallium nitride and, more recently, gallium oxide will create technological advancements that will yield a range of devices that operate with more efficiency, higher operational frequency, and smaller form factors. However, the limitation of these devices is related to thermal challenges that arise from the incredibly high-power densities (>1 kW/cm²) and high thermal resistances that can exist in some of the device architectures when traditional structures are used. The efficient thermal management in these systems must address the thermal challenges at the point where the problem is initiated, which is within the die architecture. This complex problem dictates that thermal solutions are not created in a vacuum but must consider the device's electrical performance, processing compatible with the device and scalable to wafer scale, and metrology methods to verify that the new solutions improve thermal and electrical performance. This has been a rich area of research, development, and the deployment of innovative solutions across multiple DARPA, MURI, and Industrial programs that have led to methods that can create high-power-density WBG electronics that address critical thermal limitations.

In this talk, we will cover some of the critical steps and advancements that have been developed for integrated thermal solutions at the die level of nitride and oxide semiconductor devices, with a major focus on advanced RF electronics. The talk will cover methods of thermal metrology that have been critical to the characterization of thermal properties of materials and interfaces used within the die, and how that knowledge has been used to change device architecture and process methods for device fabrication. We will discuss how surface science and advanced transmission electron microscopy have yielded new insights that provide clues into improving the thermal transport behavior at the nanoscale, which is now being implemented into new devices. In addition, material processing and integration challenges for high thermal conductivity materials from CVD growth to surface-activated bonding of diamond will be presented, and their impact on the creation of high-powered electronics. Finally, a brief discussion on how these combined metrology techniques have led to the development of AlN electronics, a new WBG system that is poised to create next-generation power electronics with inherently high thermal conductivity and process scalability.

The ultimate goal is to demonstrate the rich nature of the interdisciplinary efforts to create realistic solutions at the die level in WBG electronics and how the community can continue this trend to advance this critical technology in an integrated fashion.

Bio: Dr. Samuel Graham, Jr. is the Dean of the Clark School of Engineering at the University of Maryland, taking on this role in 2021. He is also a Visiting Professor at Nagoya University in Nagoya, Japan.



His current research centers on the development of electronics made from wide bandgap semiconductors (III-V, oxides) for a range of applications, including optoelectronics, RF communications, power switches, and neuromorphic computing. His work on wide-bandgap semiconductors focuses on engineering the thermal response of devices to enhance heat dissipation and improve device reliability. He has made seminal contributions to the thermal design and metrology of GaN electronics, including the integration of GaN and AlGaN with diamond and AlN for high-power-density devices and the design and characterization of interfaces for improved heat transfer in GaN devices. For his technical contributions, he has been appointed Fellow of ASME, AAAS, and ASTFE. He has also received the Allan Kraus Thermal Management Medal from ASME.

From 1999 to 2003, Dr. Graham was a Sr. Member of Technical Staff at Sandia National Laboratory in Livermore, CA. In 2003, he joined the Woodruff School of Mechanical Engineering at the Georgia Institute of Technology and was appointed the Eugene C. Gwaltney, Jr. Professor and School Chair in 2018 before moving to the University of Maryland in 2021.

Dr. Graham was a member of the Defense Science Study Group, a member of the Air Force Scientific Advisory Board, and a member of the Science and Technology Advisory Board of the Department of the Navy. He currently serves on the Emerging Technologies Technical Advisory Committee of the US Department of Commerce and several advisory boards for colleges of engineering within the United States.

Advanced Heat Exchangers and Process Intensification (AHXPI) Consortium

Laboratory Leadership: Drs. Michael Ohadi, Amir Shooshtari, Andres Sarmiento, and Felipe Decastro
Laboratory senior staff: Shwe Htet Htet Aung (Faculty Assistant) and Kyle Martin (Research Engineer)

Contact us for collaborations:  shwehtet@umd.edu  +1(301)-405-5412



Our Impact

Through collaborative research and innovation, AHXPI has helped achieve breakthroughs in high-performance heat exchangers, thermal management systems, and process intensification technologies.

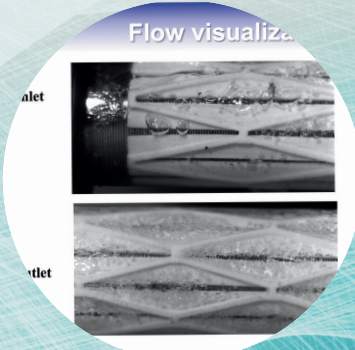
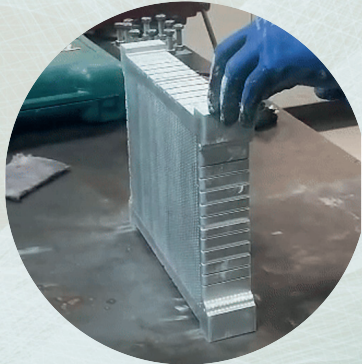
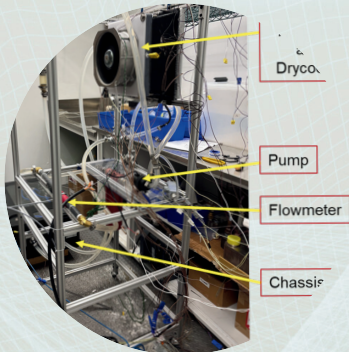

Who We Work With

- Industry partners
- Universities and research institutions
- Government agencies
- Energy and technology organizations

JOIN NOW 



S2TS Smart and Small Thermal Systems Laboratory



UNIVERSITY OF MARYLAND

If you can imagine it, we can deliver it!

ENGINEERING THE FUTURE OF THERMAL MANAGEMENT

PI: Prof. Michael M. Ohadi; University of Maryland

Contact us for collaborations:



s2ts@umd.edu



+1(301)-405-5412

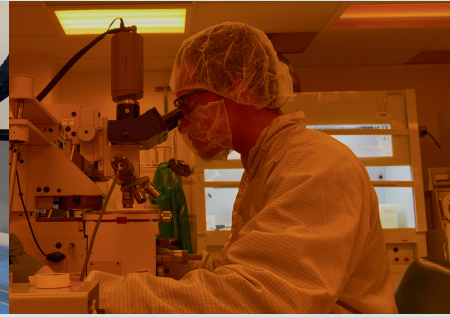
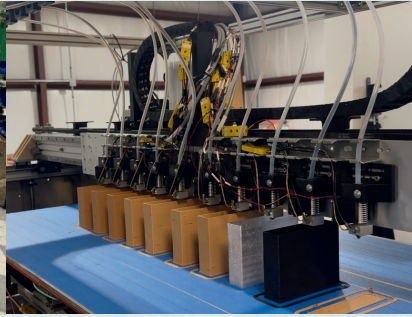
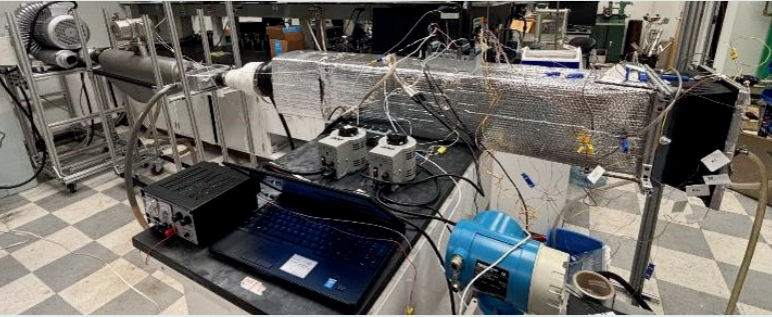

JOIN US

Advanced Heat Exchangers and Process Intensification (AHXPI) Consortium

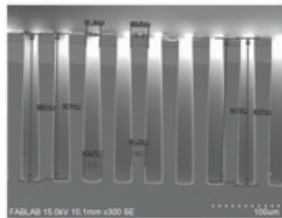
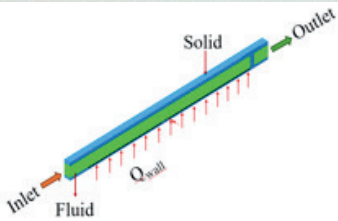

At S2TS, we develop next-generation thermal management systems using innovative design, advanced materials, and manufacturing.

Focus Areas

- Advanced heat exchangers for energy systems
- Thermal management of next-gen electronics
- Data center cooling
- Micro/Nano systems for process intensification
- Energy audit, efficiency, and resiliency analysis

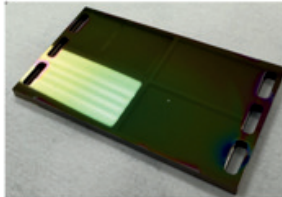
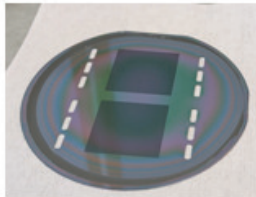

Bonded Cooler
(microchannel side)

B) Precision Liquid Chassis

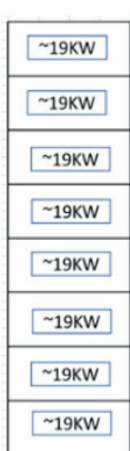

A) Rack



F) PS & RAM Emulator



C) Heat sink

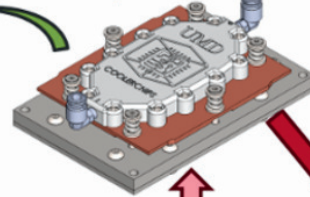

D) Heat exchanger



E) Dry-cooler

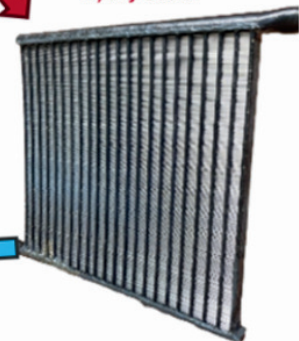

PROFESSIONAL DEVELOPMENT COURSES

A set of 16 [Professional Development Courses \(PDCs\)](#) are being offered as a collaboration between ITherm and ECTC conferences. Each of these courses are presented by world-class experts, enabling participants to broaden their technical knowledge base. All PDC courses will be held on Tuesday, May 26, 2026, the first day of the ITherm and ECTC conferences. A separate registration fee is required to attend these courses, and the PDC course registration can be performed at the ECTC registration website: <https://www.ectc.net/registration/> or at the ECTC registration desk.

MORNING COURSES 8:00 AM – 12:00 PM

1. High Reliability Soldering in Advanced Semiconductor Packaging

Course Leader: Ning-Cheng Lee – Shinepure Hi-Tech

2. Photonic Components and Packaging Technologies for Data Center, Communication, Sensing, and Displays

Course Leader: Torsten Wipiejewski – Huawei Technologies

3. Wafer-to-Wafer and Die-to-Wafer Hybrid Bonding for Heterogeneous Integration and Advanced Packaging

Course Leader: Viorel Dragoi – EV Grouk

4. Introduction to Quality and Reliability Engineering of Advanced Microelectronics Packaging

Course Leader: Shubhada Sahasrabudhe – QuRluS LLC and Shalabh Tandon – QuRluS LLC

5. 2.5D/3D Package Failure Analysis - Failure Mechanisms and Analytical Tools

Course Leader: Deepak Goyal – Carl Zeiss, Inc.

6. AI-Applications in Semiconductor Packaging

Course Leader: Pradeep Lall – Auburn University

7. Fundamentals of Fabrication Processes and RF Design of Advanced Packages Including Fan-Out, Chiplets, Glass and Polymer Interposers

Course Leaders: Ivan Ndip – Brandenburg University of Technology/Fraunhofer IZM and Markus Wöhrmann – Fraunhofer IZM

8. Electronics Cooling and Reliability for Data Centers

Course Leaders: Patrick McCluskey – University of Maryland

AFTERNOON COURSES 1:30 PM – 5:30 PM

9. Polymers for Advanced Packaging

Course Leader: Jeff Gotro – InnoCentrix, LLC

10. Diamond Heat Spreaders and Heterogeneous Integration

Course Leader: Joana-Catarina Catarina Mendes – Institute of Telecommunications

11. Advanced Packaging for Chiplet, Heterogeneous Integration, and Co-Packaged Optics

Course Leader: John Lau – Unimicron

12. Preventing Packaging Failure - Modeling and Mitigation Strategies for Warpage, Fatigue, and Thermal Issues

Course Leader: Xuejun Fan – Lamar University

13. Failure Analysis of Engineering Materials for Advanced Electronic Packaging

Course Leaders: Kuan Yew Cheong – Universiti Sains Malaysia

14. Flip Chip Technologies

Course Leader: Shengmin Wen – TATA Electronics

15. Advanced Packaging for 5G/6G - RF Focus

Course Leaders: Premjeet Chahal – Michigan State University

16. Thermal Management in the Age of AI

Course Leader: Jaime Sanchez – Qualcomm, Inc.

HETEROGENEOUS INTEGRATION ROADMAP (HIR) SPECIAL SESSIONS

TUESDAY, MAY 26, 8:30 AM – 5:00PM

ECTC

Chairs: Ravi Mahajan (Intel) and William Chen (ASE)

HIR special sessions are open to all attendees and does not require special registration.

- Quantum Infrastructure for AI Applications: Packaging Challenges and Roadmap
- Engineering Next-Generation Packaging Technologies with Advanced Substrates and Panel-Level Integration
- AI-Enabled Electronic Design Automation for Multi-Physics Advanced Packaging
- Photonics-Based Systems for AI and Exascale Computing
- System Integration Challenges of Large-Size and High-Power Components for High-Performance Computing and AI Applications
- Electrical-Thermal-Mechanical Co-Design in High-Performance Packaging
- Enabling Next-Generation Advanced Packaging Technology from Wafer to Panel
- Innovative Materials for Advanced Packaging – Materials for Packaging, Integration, and Performance

TOUR OF CORESITE ORLANDO

TUESDAY, MAY 26, 1:00 – 4:00 PM

Chairs: Milnes P. David (IBM) and Yuanchen Hu (Lightmatter)

This year ITherm will be organizing a tour to Coresite Orlando. CoreSite Orlando OR1 is a modern 129,000-square-foot facility that provides premium colocation space and access to carriers, networks and cloud providers such as AWS, MS Azure, Google Cloud and IBM Cloud. This tour provides tour attendees with a view of a modern colo facility and the interconnect, power and cooling infrastructure that supports the IT hardware. This tour requires pre-registration and can only be attended via the conference provided transportation from the JW Marriott Grande Lakes conference hotel.



YOUNG PROFESSIONALS NETWORKING PANEL

TUESDAY, MAY 26, 7:00 – 7:45 PM

ECTC

Chair: Aakrati Jain (IBM)

Join us for an invaluable opportunity to connect with industry leaders and fellow emerging talents! Tailored specifically for young professionals, including current graduate students, this event is crafted with your needs in mind. Engage in dynamic interactions with senior EPS members and professionals through a series of active and engaging activities. Seize the chance to delve deeper into packaging-related topics, pose career questions, and connect with industry professionals for a valuable learning experience.

The Intersection of Interconnection

Increasingly complex digital business demands require infrastructure performance and flexibility. We deliver purpose-built data centers and a highly interconnected ecosystem that holistically ensures you can optimize customer experience, scale on-demand and grow your business.

INCREASING REVENUE, DECREASING COSTS

Our enterprise customers increase revenue by interconnecting to our digital ecosystem, creating greater value for their customers and partners, inspiring brand loyalty and expanding market reach.

Digital platform and managed services providers recognize the immense potential to add value to, and attract more businesses into, digital ecosystems. Our network-dense, scalable and cloud-connected data centers provide an “intersection of interconnection” for you and your customers.

SIMPLIFYING INTERCONNECTION, DATA CENTER MANAGEMENT

30

Network-dense data centers in 10 key markets

435+

Network providers

325+

Cloud and IT solutions providers

40K+

Customer interconnections



MyCoreSite comprehensive service delivery platform



Open Cloud Exchange® Automated network services platform

WHERE YOU PUT YOUR INFRASTRUCTURE MATTERS

Throughout the U.S., CoreSite provides secure, reliable, high-performance cloud-enabled data center solutions to support the mission-critical IT infrastructure requirements of leading companies.

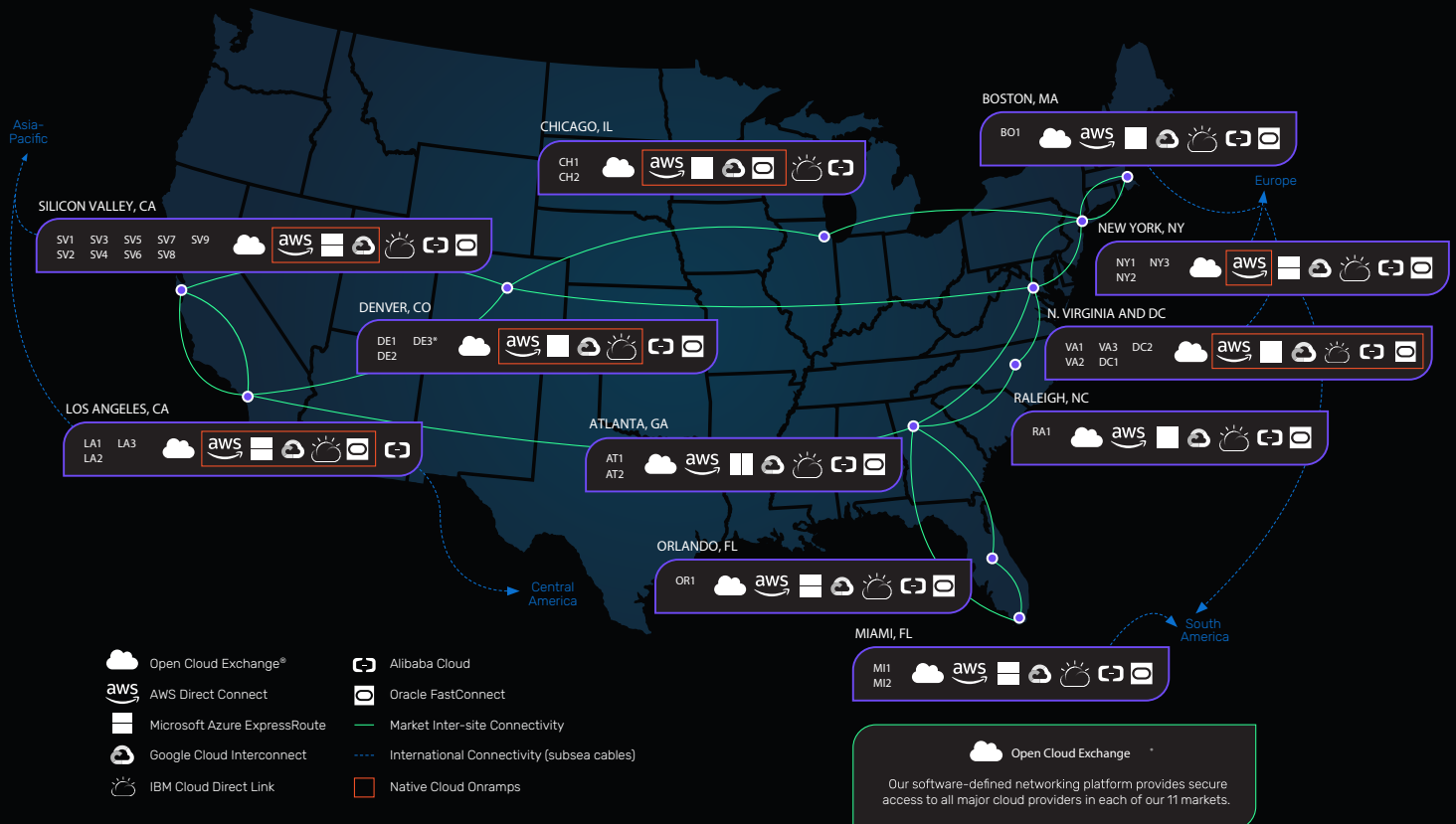

THE OUTCOMES

MONETIZE YOUR BUSINESS

Our Open Cloud Exchange® (OCX) enables collaboration with all the partners in your digital ecosystem. Our proprietary platform provides direct, secure and virtual connections to anyone on the exchange – enabling businesses to quickly turn up connections, transfer content and collaborate in real-time. The OCX empowers our customers to complete unique production projects and achieve a faster time to market.

MEET STRINGENT COMPLIANCE REGULATIONS

Many businesses strive to provide excellent customer experience but are challenged by compliance regulations designed to protect customer data. CoreSite's data centers satisfy stringent compliance regulations and provide the multi-layered security features, 100% uptime service level agreement (SLA) and infrastructure resilience needed to support an excellent customer experience.

FUTURE-PROOF YOUR DIGITAL BUSINESS

Enterprises in myriad industries deploy multicloud and hybrid IT strategies at CoreSite to achieve better performance. Our agnostic approach and strategic partnerships enable customers to quickly connect to their preferred cloud providers to maximize performance and take advantage of the latest cloud application or workload.

“When we joined CoreSite, everyone laid down the red carpet in the pre-sales stage – and the red carpet stayed down since we have become customers. Our experience continues to be phenomenal.”

PRINCIPAL NETWORK ENGINEER AT A FEDERAL CREDIT UNION

WHY CORESITE?

We are building the digital infrastructure for tomorrow, today, as a subsidiary of American Tower. The combined assets of the companies – CoreSite's data centers, decades of operational experience and unique interconnection platform and American Tower's domestic and international real estate portfolio – establishes a differentiated foundation for building the interconnection fabric of the future and accelerating wireline and wireless convergence. Additional reasons are rooted in our demonstrated ability to deliver a significant return on investment:

- **Save up to 60%** on CoreSite cloud connectivity compared to traditional telco and SDN offerings*
- **Save up to 50%** by connecting to 435+ network service providers at CoreSite*
- **Cut data replication costs by as much as 70%** using direct interconnection and eliminate data egress costs when restoring data from certain local cloud availability zones*

NATIVE ONRAMPS TO ALL MAJOR CLOUD PROVIDERS



Microsoft Azure



ORACLE
CLOUD



*Costs savings are based on CoreSite cost comparisons using publicly available and private information and/or CoreSite customer reported costs savings and may not be indicative of the costs savings that may be experienced by every customer that switches to the applicable CoreSite service.



CoreSite.com | +1 866.777.CORE | Info@CoreSite.com



***Yours for
the making***

intel foundry

ITHERM STUDENT MIXER

WEDNESDAY, MAY 27, 5:30 – 8:30 PM

LOWER LEVEL, SEGURA 1-4

Chair: Felipe Valenzuela-Gaete (IBM)

This year we will have a Student Mixer event together with the Student Design Challenge. Come enjoy beverages and tapas while networking with your peers and supporting your fellow students at the student design challenge. Other fun ice-breaker activities are also planned for this time!

ITHERM 25TH ANNIVERSARY CELEBRATION

THURSDAY, MAY 28, 1:00 – 2:00 PM

LOBBY LEVEL, PALAZZO EFGH

This year marks the 25th iteration of ITherm. Join us for a special retrospective panel and celebration during the Thursday luncheon. We look back at the humble beginnings of our conference, how it has grown, the challenges we have faced as a discipline, and looking ahead to the next 25 conferences. We will be joined by five distinguished members of the thermal field and long-standing leaders and contributors to ITherm, EPS and IEEE.

PANELISTS

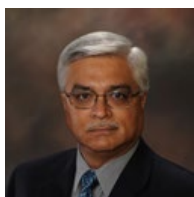

Sushil Bhavnani
Auburn University

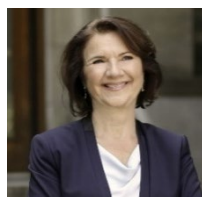

Cristina Amon
University of
Toronto



Alfonso Ortega
Villanova
University



Dereje Agonafer
University of
Texas - Arlington



Paul Wesling
IEEE

ART IN SCIENCE EXHIBITION

WEDNESDAY, MAY 27 – FRIDAY, MAY 29

LOWER LEVEL

Chairs: Pranay Nagrani (IBM) and Amir Shooshtari (UMD)

The Art-in-Science exhibition returns to ITherm this year! This event provides a fun opportunity for the ITherm and thermal community to showcase the artistic side of their work. Authors share their creativity through images and artwork produced during their scientific explorations and technical implementations, displaying heat and mass transfer and thermo-mechanical phenomena. This year also sees the introduction of AI tools in producing artwork through remixes and enhancements. Look through this program to find the entries that were submitted. Winners of the exhibition will be announced during the awards luncheon on Friday.

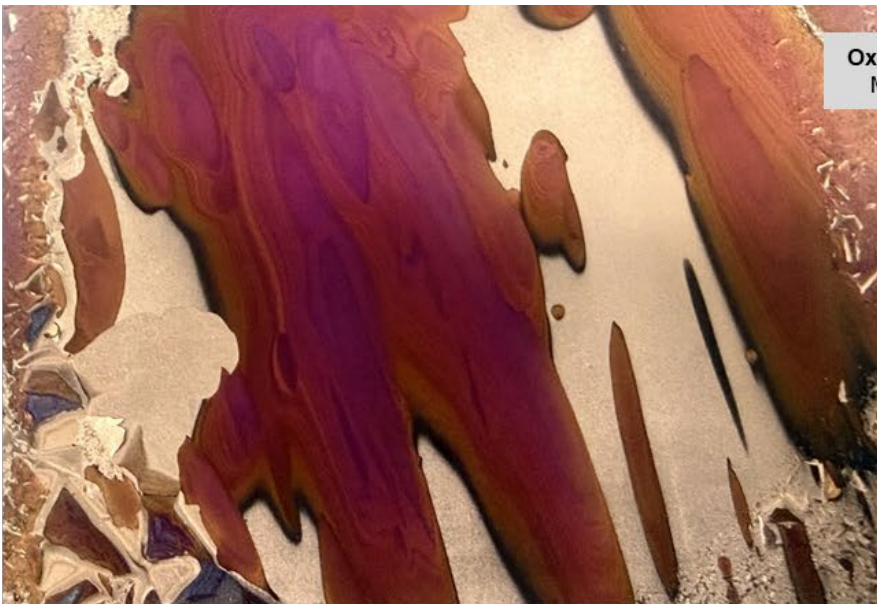

Oxides in Cascade
Matthew Norris

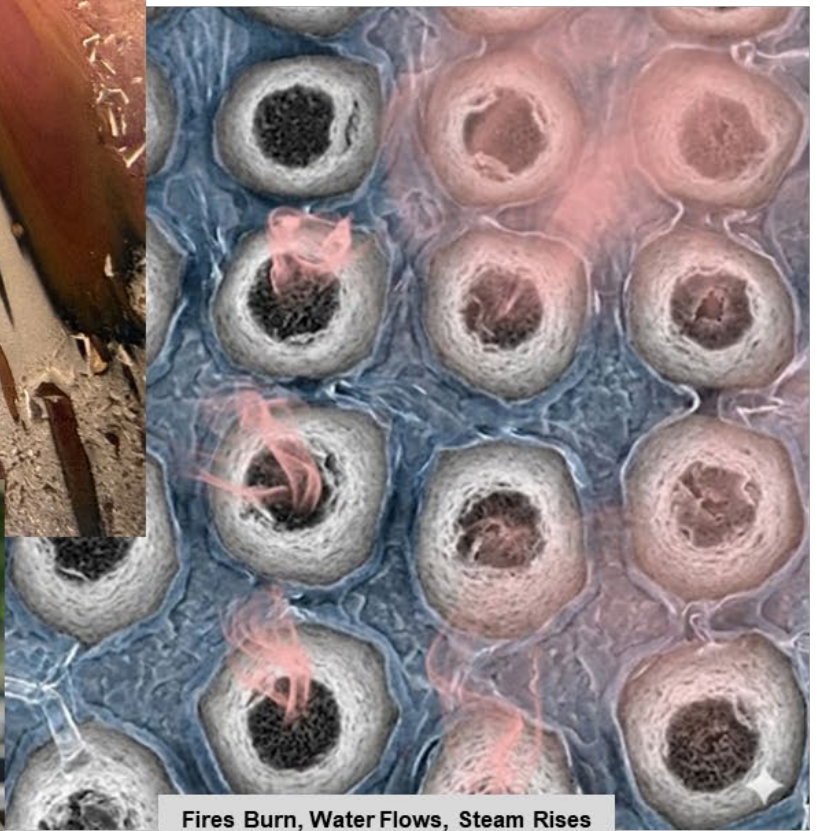

Fires Burn, Water Flows, Steam Rises
Mehdi Asheghi



Dendrite Growth Mechanism
Young Jin Lee

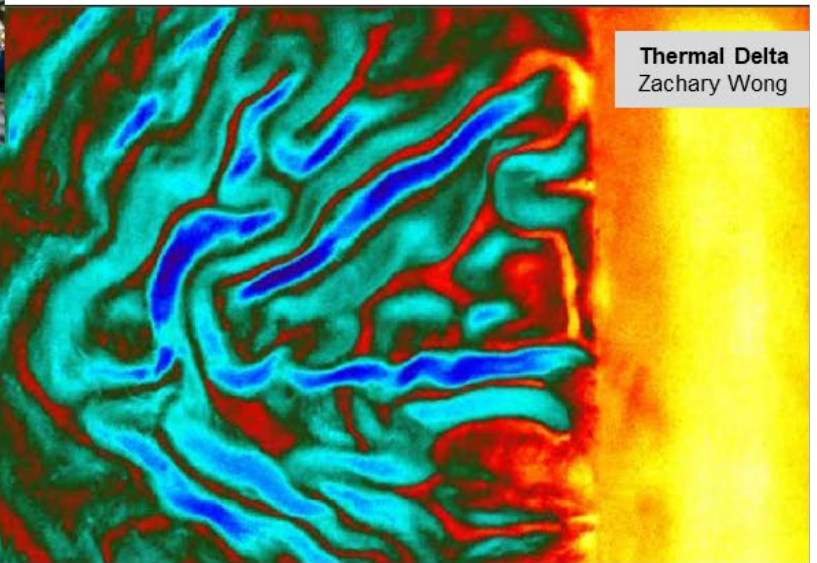

Thermal Delta
Zachary Wong

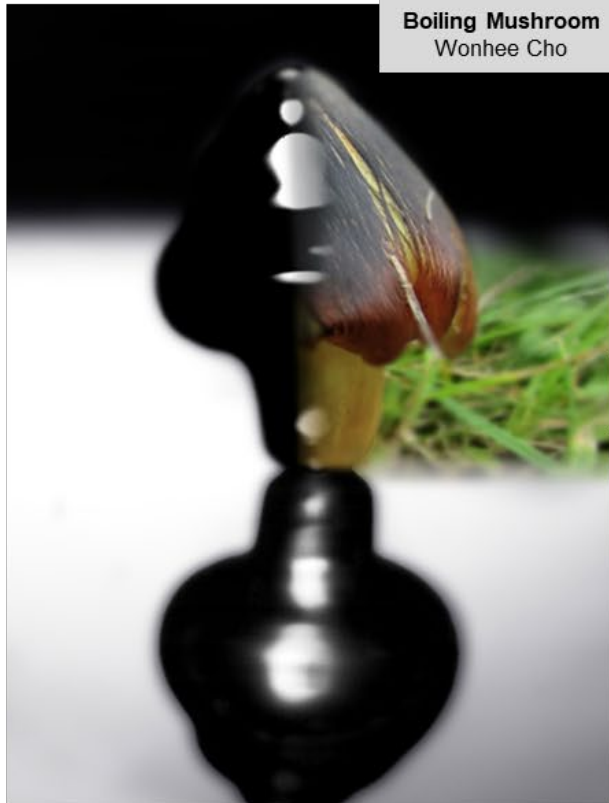

Boiling Mushroom
Wonhee Cho

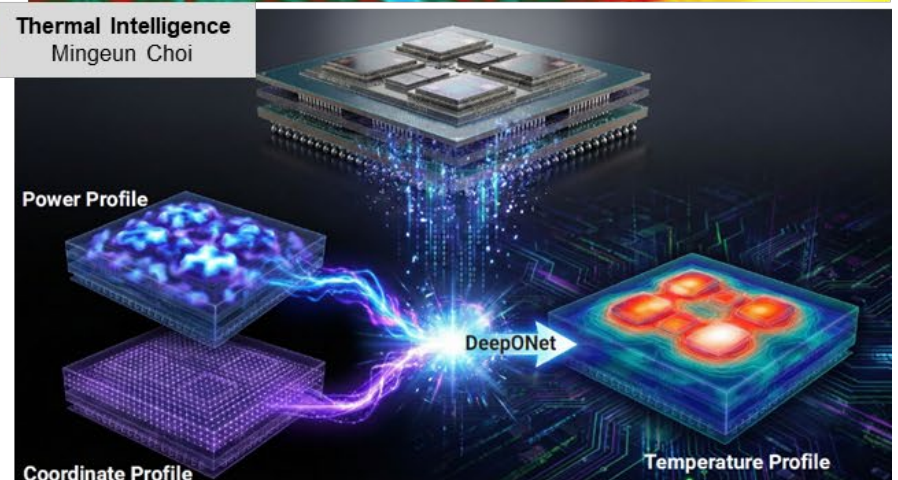

Thermal Intelligence
Mingeun Choi

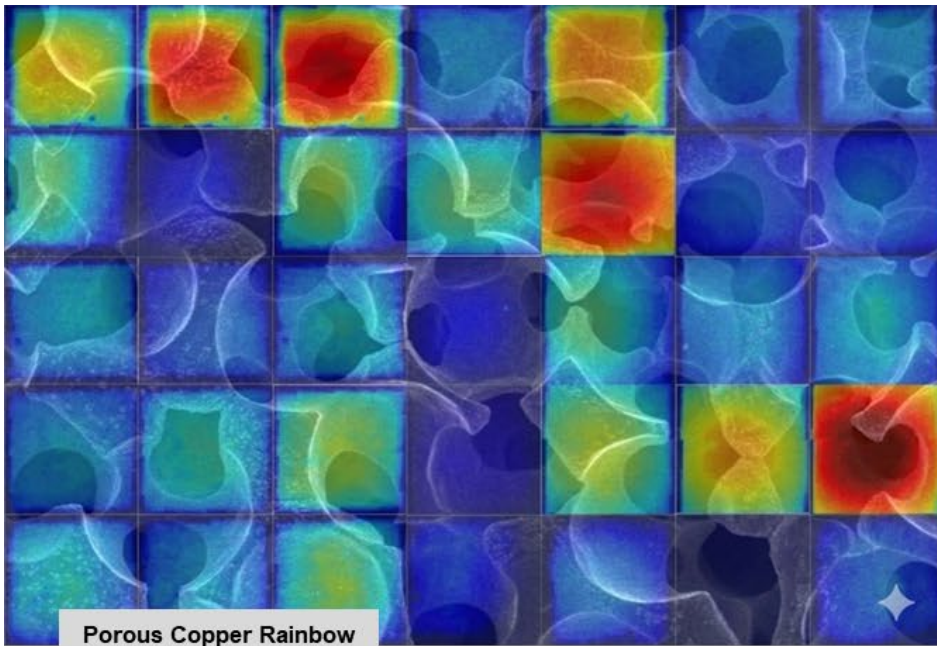

Porous Copper Rainbow
Mehdi Asheghi



A Dance of Heat and Matter
by Sabina Bimali

A Dance of Heat and Matter
Sabina Bimali

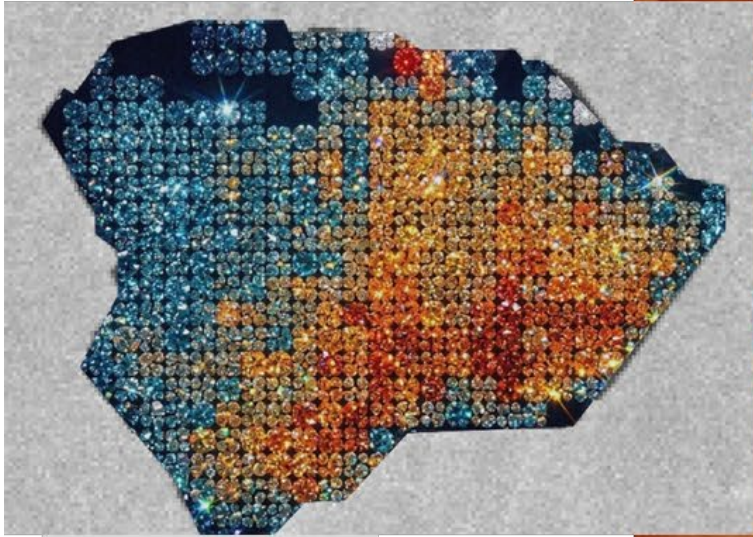

The Silent Sparkle of Heat
Luke Min

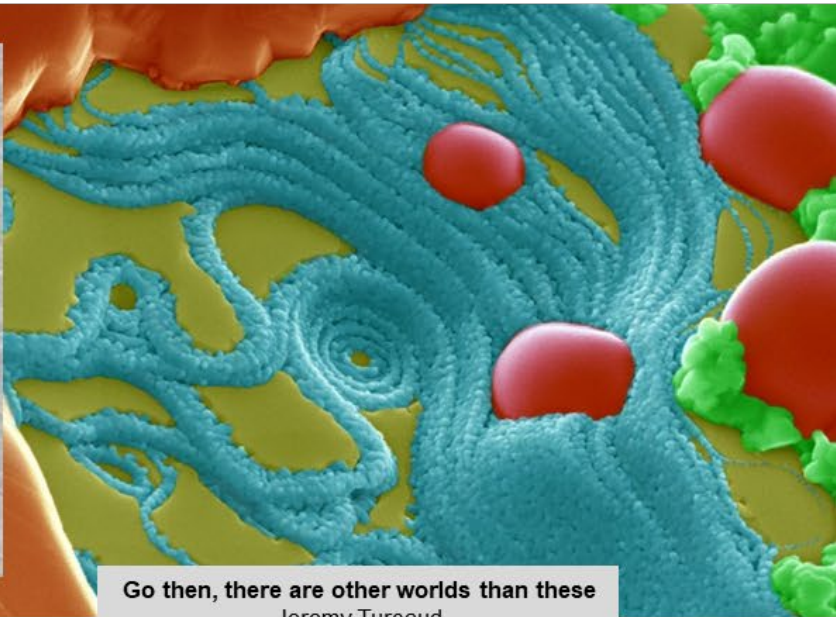

Go then, there are other worlds than these
Jeremy Turcaud



Thermal Tides
Max Kusnierz

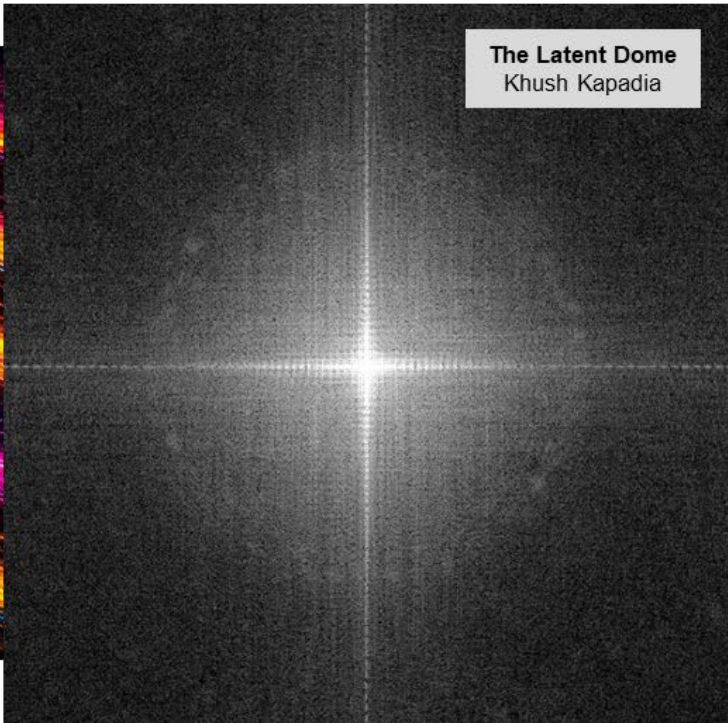

The Latent Dome
Khush Kapadia

STUDENT POSTER & NETWORKING SESSION

THURSDAY, MAY 28, 5:30 – 7:00 PM

LOWER LEVEL, SEGURA 1-4

Chairs: Aakrati Jain (IBM) and Kalind Baraya (IBM)

In this interactive session, students present their research and network with conference attendees from industry and academia. For employers, this is a great chance to find your next talented engineering hire! Outstanding posters will be selected for awards and will be judged based on technical merit, clarity and self-sufficiency of the content, novelty and originality of the work, overall impact of the poster display, and oral presentation at the poster session.



POSTER & NETWORKING SESSION AT IThERM 2025, DALLAS TX



ITHERM 2025 POSTER AWARDS

BEST OVERALL POSTER

TOPOLOGY OPTIMIZATION FOR EMBEDDED COOLING OF MULTIPLE AND TRANSIENT WORKLOADS IN 3D SEMICONDUCTOR PACKAGES

Zekun Wu, Purdue University (Prof. Lian Pan & Prof. Justin Weibel)

COMPONENT-LEVEL THERMAL MANAGEMENT TRACK

BEST POSTER

MULTIPHYSICS TOPOLOGY OPTIMIZATION OF METAL-POLYMER COMPOSITE THERMAL INTERFACE MATERIALS

Devang Tavkari, Purdue University (Prof. Amy Marconnet & Prof. Tiwei Wei)

RUNNER-UP

FLASH BOILING OF METHANOL/WATER MIXTURES IN A MICROCHANNEL COOLER

Naarendharan Meenakshi Sundaram, UCLA (Prof. Timothy Fisher & Prof. Subramanian S Iyer)

SYSTEM-LEVEL THERMAL MANAGEMENT TRACK

BEST POSTER

PREDICTING MULTISCALE THERMAL TRANSPORT IN HIGH-CAPACITY POUCH-TYPE LITHIUM-ION BATTERIES FOR STATIONARY ENERGY STORAGE SYSTEMS

Oscar Alvarez Lemus, University of Toronto (Prof. Cristina Amon)

RUNNER-UP

RATE OF THERMAL ENERGY STORAGE IN COMPOSITE PHASE CHANGE MATERIAL SLABS

Derian Morphew, Texas A&M University (Prof. Patrick J. Shamberger)

EMERGING TECHNOLOGIES AND FUNDAMENTALS TRACK

BEST POSTER

FABRICATION AND EXPERIMENTAL EVALUATION OF BENDABLE COPPER FLAT-PLATE OSCILLATING HEAT PIPE

Ishan Tandon, Purdue University (Prof. Justin Weibel)

RUNNER-UP

AN EXPERIMENTAL STUDY OF THE THERMAL-HYDRAULIC PERFORMANCE OF AN ADDITIVELY MANUFACTURED MINI-CHANNEL COLD PLATE

Zane Oligea, Auburn University (Prof. Nicholas Tsolas)

RUNNER-UP

POOL BOILING ENHANCEMENT USING ENGINEERED NUCLEATION SITES

Priyanka Viswanath, University of Michigan, Ann Arbor (Prof. Solomon Adera)

MECHANICS AND RELIABILITY TRACK

BEST POSTER

IMPACT OF NON-FLAT HEAT SINK SURFACE ON DEGRADATION OF THERMAL GREASES

Ritwik Kulkarni, Purdue University (Prof. Amy Marconnet)

RUNNER-UP

HUMIDITY AND HIGH-TEMPERATURE EFFECTS ON NON-PFAS THERMAL INTERFACE AND UNDERFILL MATERIALS

Padmanava Choudhury, Auburn University (Prof. Pradeep Lall)

RUNNER-UP

THERMAL CONDUCTIVITY EVOLUTION OF NON-PFAS AUTOMOTIVE PACKAGING MATERIAL UNDER HIGH TEMPERATURE AND HUMIDITY EXPOSURE

Yunli Zhang, Auburn University (Prof. Pradeep Lall)



Georgia Tech College of Engineering

George W. Woodruff School of Mechanical Engineering

Micro Nano Devices and Systems Lab (MiNDS)

<https://sites.gatech.edu/minds/>



Experimental investigation of subcooled flow boiling in an immiscible fluid mixture of 33% Eutectic Galinstan and IPA at an inlet velocity of 0.35 m/s and a heat input of 90 W. The addition of Galinstan provides effective nucleation sites, resulting in enhanced boiling and improved heat transfer.

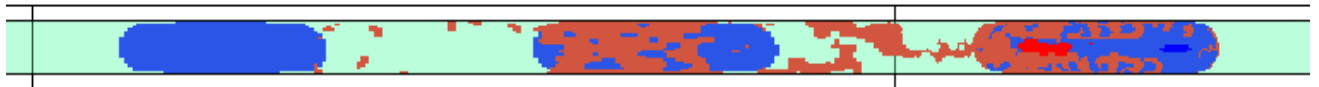

3-Phase Contours from CFD simulations of subcooled flow boiling in an immiscible fluid mixture of 33% Eutectic Galinstan and IPA at an inlet velocity of 0.35 m/s and a heat input of 75 W. Galinstan: Blue; IPA: Green; and Vapor: Brown/Red.

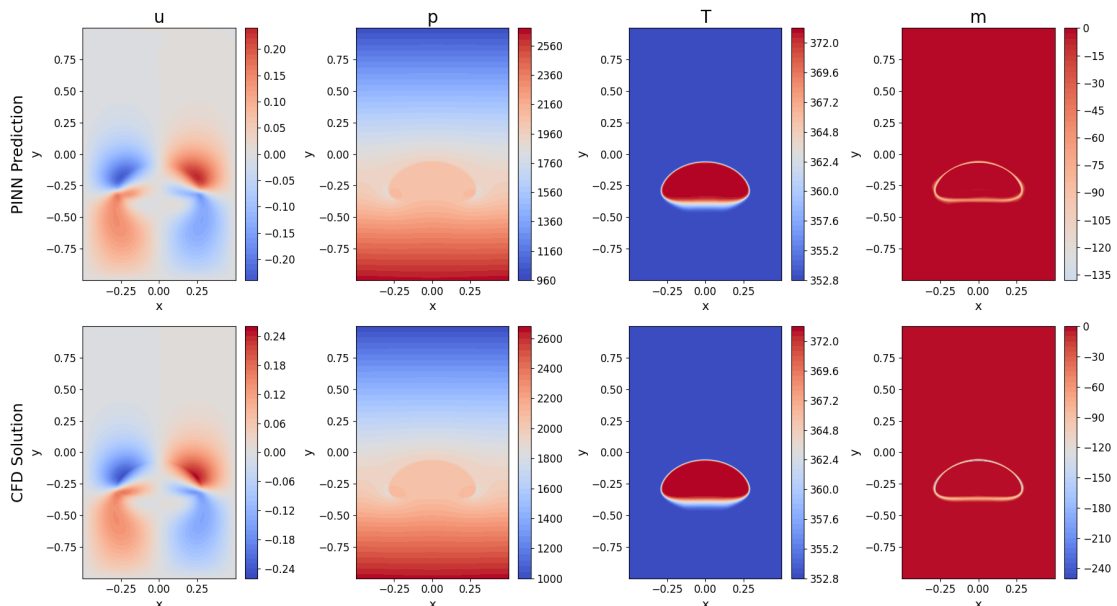

Physics Informed Neural Networks (PiNNs) to predict velocity, pressure, temperature, and spatiotemporal mass transfer in a condensing bubble rise case using a CFD generated synthetic dataset representing experimentally feasible data.



Georgia Tech College of Engineering
**George W. Woodruff School
of Mechanical Engineering**

**Microelectronics and Emerging
Technologies Thermal Lab (METTL)**

<https://mettl.gatech.edu/>

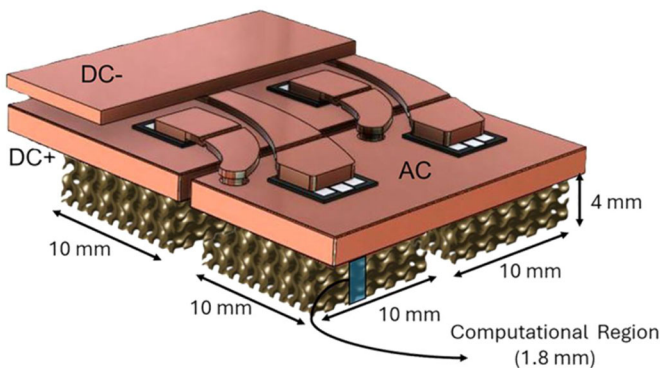

Conceptual half-bridge module for the use of dielectric fluid and TPMS structure

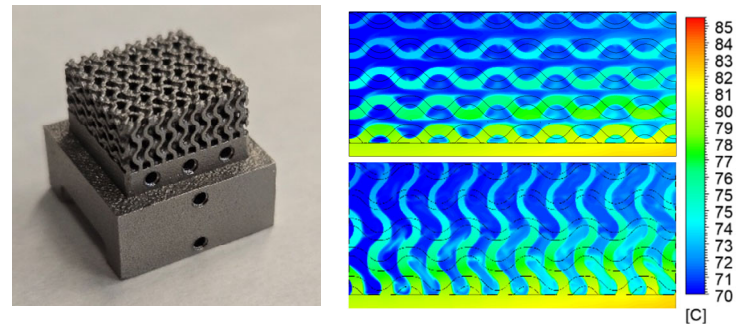

3D printed Triply Periodic Minimal Surface (TPMS) lattice structure and temperature distribution in solid and fluid parts featuring functionally graded porosity, exposed to a constant heat flux.

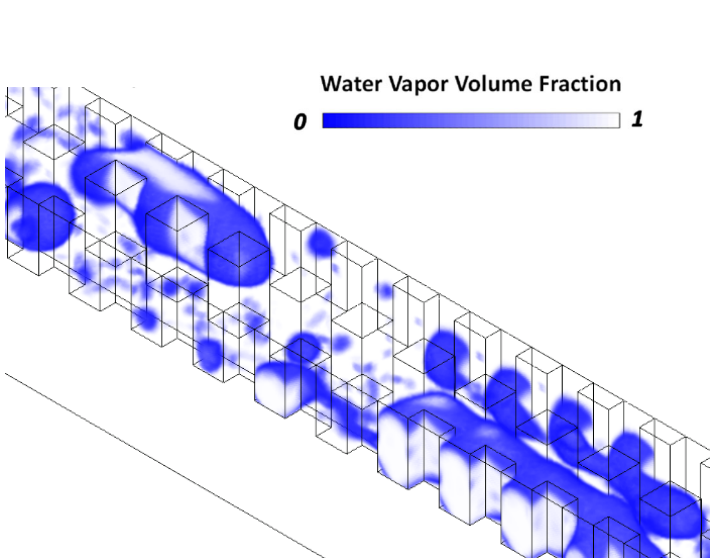

Quasi-steady flow regime development depicting bubbly-slug flow in the mid-section of a pin-fin enhanced microgap

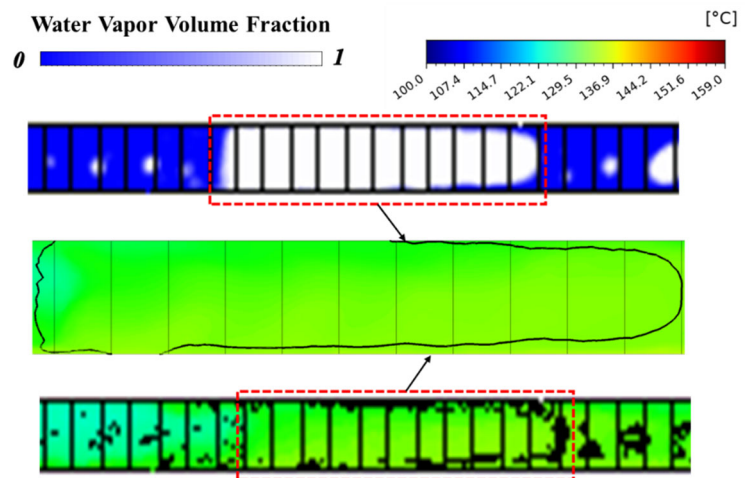

x-y cross-sections between the pin-fins showing pseudocolor maps of volume fraction and quasi steady temperature distribution; magnified view of temperature distribution for a bubble overlaid with contours of constant volume fraction $\alpha = 0.5$ in the mid-section of the pin-fin enhanced microgap

ASME/K16 & IEEE/ EPS STUDENT DESIGN CHALLENGE

WEDNESDAY, MAY 27, 5:30 – 8:30 PM

LOWER LEVEL, SEGURA 1-4

The ASME K-16 Student Design Competition is an annual international engineering challenge, organized by the ASME K-16 Committee in collaboration with IEEE ITherm, that engages student teams in designing advanced thermal management solutions for electronic systems. Each year, participants are tasked with creating, analyzing, and optimizing a component, such as a heat sink or liquid-cooled cold plate leveraging additive manufacturing techniques to maximize thermal performance while meeting design constraints. Teams submit technical analyses and white papers, after which top designs are selected, fabricated, and experimentally tested; finalists present their results at the ITherm conference and are evaluated based on performance, innovation, and communication quality. The competition emphasizes real-world engineering skills, including simulation, design optimization, and experimental validation, while fostering collaboration between academia and industry.

OVERVIEW OF COMPETITION GUIDELINES

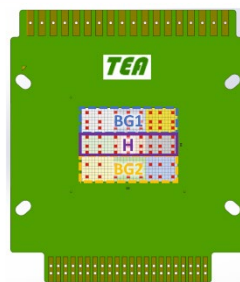
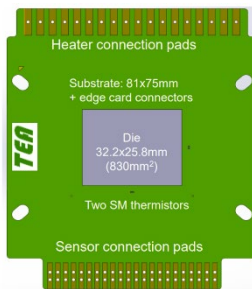
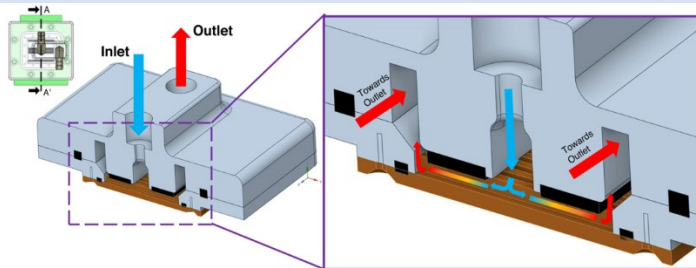

Flow Configuration

Coolant Fluid:	PG-25
Coolant Flow Rate:	1.2 lpm
Inlet Temperature:	30°C
Ambient Temperature:	20°C
TIM Resistance:	0.03 cm²K/W

Thermal Test Vehicle

Zone H (center):	400 W
Zone BG1 (top):	200 W
Zone BG2 (bottom):	200 W

Figure of Merit

$$FOM = 0.7 \frac{R_{baseline} - R_{max}}{R_{baseline}} + 0.3 \frac{\Delta P_{baseline} - \Delta P}{\Delta P_{baseline}}$$

ORGANIZING TEAM

Amy Marconnet (Purdue)
Tiwei Wei (UCLA)
 Lang Yuan (Oracle)
 Han Hu (U. of Arkansas)
 Tianli Feng (U. of Utah)
 Vish Ganesan (UIUC)
 John Holaday (Purdue Applied Research Lab)
 Gabe Velarde (Purdue Applied Research Lab)
 Dongkai Shangguan (TEA, Indum Corp.)

- **Test System Design: UCLA S-PACK Lab:**
Tiwei Wei (UCLA), Akshat Patel, Yunchun Yang, and Ketankumar Yogi
- **Fin Plate Printing: Fabric8Labs:**
Ian Winfield, Tanner Immonen, Gautam Gupta, Mike Matthew, and Jim Golden
- **Testing: Georgia Tech Micro Nano Devices & Systems (MiNDS) Lab:**
Satish Kumar and Dakshi Adhikari
- **Manifold Fabrication: IBM:** Pritish Parida

FINALISTS

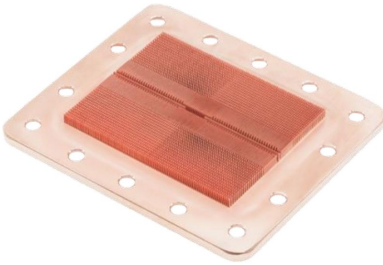

MSAM MDAM

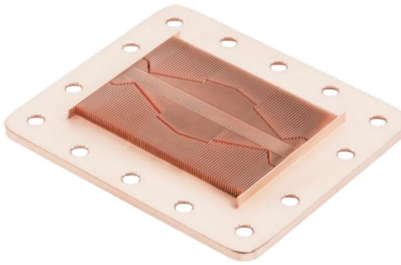

NERL-MNEMS

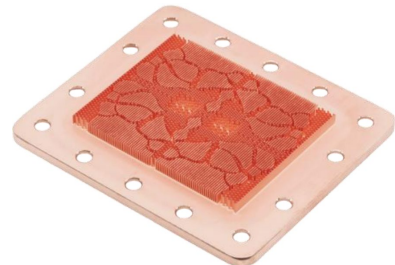

Microaero

SPONSORS

Print Sponsor



Simulation Sponsor



Testing Sponsor

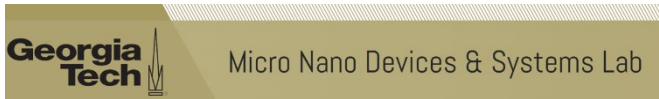

Manifold Fabrication Sponsor



Experimental Design Sponsor



TIMs Sponsor

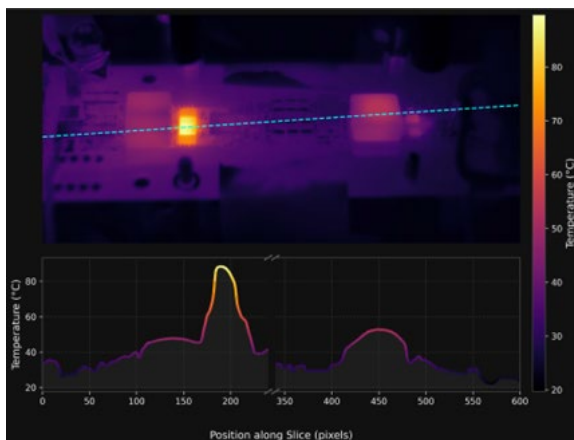

Pão De Açucar at 60 Amps
Zachary Wong



The Mending
Krithik Senthilkumar

Beijing Simulation World Engine Co., Ltd.

We are a professional physics-based simulation company in China. As an innovation practitioner, we are committed to providing the critical infrastructure and foundational data of physical AI. With self-developed physics-based simulation technologies, we have successfully launched and commercialized the Simdroid Platform, our general-purpose simulation solutions, supporting a wide range of solvers across four major physics domains, namely structural mechanics, fluid dynamics, electrodynamics, and thermodynamics. It features a GPU-native and unified multiphysics architecture and a digital twin model library of over 200,000 models.

Building on Simdroid Platform, we have developed several specific simulation solutions tailored to target industries and application scenarios to address the highly specialized requirements of customers. Notably, we have successfully launched and commercialized Simdroid-EC, designed for thermal simulation and deeply integrated with AI technologies. It is widely used in the electronic information industry.

Simdroid-EC Simdroid Electronic Cooling

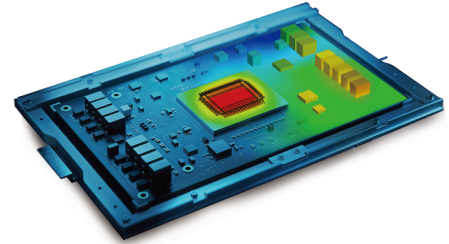

Simdroid-EC is a specific simulation solution designed for thermal management of electronic components and devices, providing high-accuracy and high-efficiency thermal simulation solutions from the chip level to the system level. Relying on our advantages in high-performance computing, AI-driven thousand-fold speedups, and automated simulation workflows, Simdroid-EC has achieved large-scale deployment and commercialization.

Major Application Scenarios

- Chip and package-level thermal design and analysis
- PCB and module-level thermal design optimization
- Full-scale thermal simulation analysis for mobile phones, tablets, chassis, and cabinets
- System-level ventilation and cooling simulation for large computer rooms and data centers

Chip level

BGA Chip Thermal Analysis

PCB level

PCB Thermal Analysis

Device Level

Router Heat Dissipation Analysis

System Level

Data Center Airflow Analysis

Cutcell Mesh

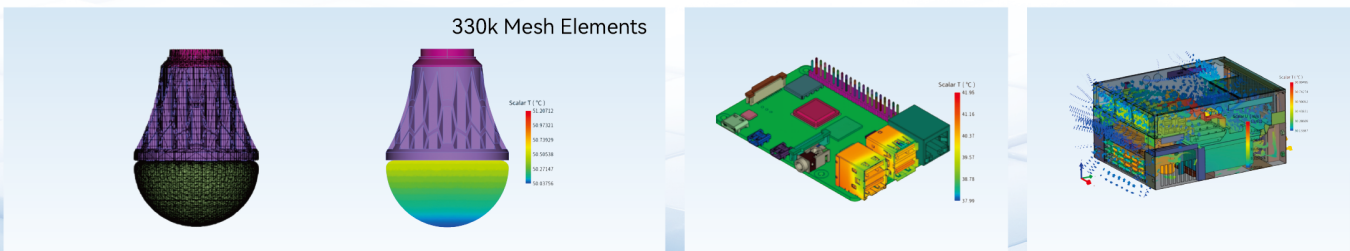

GPU-native Architecture

We have achieved up to 50-fold acceleration in explicit dynamics simulation scenarios through GPU parallel computing, significantly enhancing the efficiency of solving complex engineering problems.



Deep Integration of AI Technologies

AI Surrogate Model

Reduce solve times to seconds while maintaining precision

	Surrogate model prediction (°C)	Simulation result (°C)	Absolute error (°C)	Accuracy (%)
Maximum temperature	62.95	62.93	0.02	99.97
Minimum temperature	34.36	34.36	0	100

Exceptional Performance

AI Agent

Democratize simulation with natural language

7/24 Knowledge Base Automation

Intelligent Workflow

Contact Us

📍 Floors 1-2, Block A, Building 5, Zhongguancun Dongsheng International Science Park, No.1 Yongtaizhuang North Road, Haidian District, Beijing, 100192, China

☎️ +86-10-82363065 ✉️ info@simwe.com 🌐 www.simwe.com

Achieve unparalleled levels of chip cooling with Element Six's leading CVD diamond and Cu-Diamond thermal management solutions

Element Six (E6) is a world-leading provider of synthetic diamond-enabled engineered solutions. We supply a range of advanced materials for demanding thermal management applications, including our leading chemical vapor deposition (CVD) diamond and copper-diamond composite (Cu-Diamond).

E6's diamond solutions are ideal for a range of heat spreading and heat sinking applications in high-power density semiconductor devices, including high TDP AI chips, RF power amplifiers, power modules, and high-power semiconductor lasers.

CVD diamond thermal grades

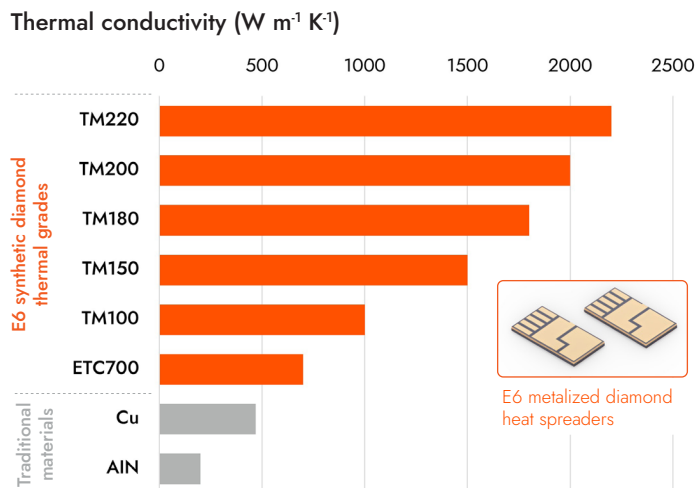

Thermal conductivity: 1000 - 2200 $\text{W m}^{-1} \text{K}^{-1}$
Thermal expansion coefficient: 1 ppm K^{-1}

Advantages

- Reduce thermal management bottlenecks
- Improve thermal performance of the device package
- Increase device reliability
- Enhance output power
- Reduce cooling requirements

Cu-Diamond

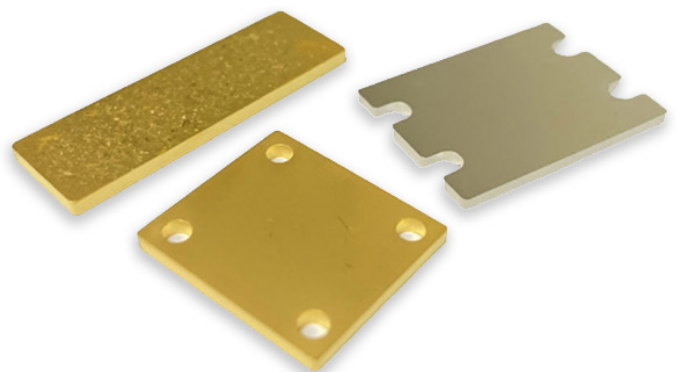

Thermal conductivity: 800 - 1000 $\text{W m}^{-1} \text{K}^{-1}$
Thermal expansion coefficient: ~7 - 9 ppm K^{-1}

Availability

E6's synthetic diamond materials can be supplied in sizes ranging from a few millimeters to several centimeters, and can be coated with thin metal layers, such as Au and Ni, for compatibility with standard die attach bonding. Complex shapes and tailored solutions can be produced according to customer requirements. Further details are available upon request.

TECHNOLOGY-TALKS

Chairs: Georges Pavlidis (University of Connecticut), Qian Han (Luxshare)

TT-01: THERMAL PACKAGING IN AVIATION/SPACE DEFENSE SYSTEMS

WEDNESDAY, MAY 27, 8:00 – 9:15 AM

LOWER LEVEL, AMARANTE 2-3



ADVANCED PACKAGING FOR EFFICIENT MICROELECTRONICS THERMAL MANAGEMENT

Clayton Pullins
Northrop Grumman

Abstract: Despite significant attention over the last several years, thermal management remains a cornerstone challenge of microelectronics packaging today. Novel packaging techniques that enable Three-Dimensional Heterogeneous Integration (3DHI) must be utilized to incorporate local heat spreading within and effective heat removal from microelectronics packages. Bootstrapped thermal management solutions will not meet the requirements of next-generation 3DHI microelectronics. Instead, upfront co-design efforts must address the intertwined challenges of performance, reliability, durability, scalability and affordability, with thermal management at the nexus. This talk will highlight several emerging advanced packaging technologies and their utility for improving microelectronics thermal management. 3DHI design and assembly topics to be discussed include material (conductor, semiconductor and dielectric) selection and integration, thermocompression bonding, oxide and hybrid (oxide + copper) bonding, solder hierarchy, and differential thermal expansion. Additionally, the role each of these topics plays in enabling efficient package thermal management will be explained. Finally, the responsibility that microelectronics integrators have to address these microelectronics packaging and cooling challenges will be discussed.



MICROFLUIDIC COOLING INTEGRATED INTO GLASS SUBSTRATES

Edward Horne
3D Glass Solutions

Abstract: Microfluidic cooling channels inside glass substrates provide advanced thermal management for aviation and space systems. In this work a liquid cooled glass-based interposer architecture is presented with all the standard features of a typical interposer including top side IC assembly, RDL redistribution layers, bottom side BGA/LGA footprints, and through glass vias (TGVs). Microfluidic cooling channels are also created inside the substrate by a unique photosensitive glass process. Traditional passive cooling thermal vias are also present inside the cooling channel which provide standard vertical thermal conduction but also provide convection surface cooling when a liquid coolant is flowed through the channel. 3DGS is able to fabricate microfluidic cooling channels in widths from 10's of microns to 100's of microns in glass substrates ranging in thickness from 100 microns to >1000 microns. Multiple design variants have been fabricated which show measured heat transfer reaching 22 W/cm²K. CFD simulations show volumetric flow rates which match measured results of 230 mL/min at 50 psi. A 40W heat source placed above the cooling channel only increases in temperature by less than 5°C in simulation. Next generation designs will include active power amplifiers assembled on top of the cooling channels to demonstrate increased PA output power and efficiency. Active microfluidic cooling can also be integrated into 3DHI stacked glass phased array modules showing significant SWaP-C improvement for aviation and space systems.

TT-03: ADVANCES IN DATA CENTER COOLING AND INTELLIGENT THERMAL CONTROL

WEDNESDAY, MAY 27, 2:00 - 3:30 PM

LOWER LEVEL, AMARANTE 2-3



THE ROLE OF HIGH-PERFORMANCE COMPUTING FOR THE ADVANCEMENT OF MULTI-PHASE HEAT TRANSFER FLOWS IN ELECTRONICS COOLING

Wangda Zuo
Pennsylvania State University

Abstract: As data centers become the backbone of the digital economy—driven by rapid growth in AI, cloud computing, and high-performance computing—cooling systems are emerging as both a critical constraint and a major source of energy use, growing more complex with higher rack densities, thermal variability, liquid cooling adoption, and tighter grid interaction. These challenges demand a shift from incremental improvements to a new paradigm for modeling and control, which this talk explores through the progression from Modelica-based system modeling to the broader vision of Physical AI. Modelica, an equation-based, object-oriented language, enables unified, physics-based modeling of coupled thermal, fluid, electrical, and control systems, making it well suited for creating modular, scalable digital twins of data center cooling infrastructure that support design, performance evaluation, fault detection, and control optimization, as demonstrated through a DOE-funded case study. Building on this foundation, the talk introduces Physical AI, which integrates first-principles models with real-time data and machine learning to create adaptive, explainable, and operationally intelligent systems, transforming static models into living digital intelligence capable of predicting behavior, generating synthetic data, coordinating cooling with IT loads, and enabling autonomous optimization of next-generation data center operations.



FROM GRID TO CHIP TO AMBIENT: HOW AI FACTORY ENERGY-STACK SYSTEM POWER AND HOT -WATER COOLING ENGINEERING CAN DELIVER LEAPS IN ENERGY EFFICIENCY

Peter de Bock
Eaton

Abstract: AI data centers have evolved from facilities into city-scale energy systems, where rising rack densities, compressed deployment timelines, and grid constraints require a shift from traditional enterprise design to an integrated energy stack spanning grid interconnection, power conversion, compute delivery, and thermal management—making system-level engineering far more effective than component-based approaches. Three tightly coupled power domains—IT power (moving from 480 V AC toward 800 V DC), whitespace cooling (now an availability-critical load), and centralized cooling plants (best served by medium voltage)—must scale together, as physics, current, and fault domains dictate both footprint and reliability. The most powerful efficiency lever is no longer equipment, but the temperature delivered to silicon, where advances in cold plate design and chip architecture enable higher-temperature cooling and reduced chiller demand, shifting focus to maximizing compute per watt and making thermal resistance a key driver of overall system performance. At gigawatt scale, resilience depends on coordinated power quality, ride-through for critical cooling, and intelligent monitoring systems that transform infrastructure into actively managed assets. Ultimately, AI facilities are becoming integrated, living energy systems, and competitive advantage will go to those who design the full energy stack holistically, using innovations like hot-water cooling to unlock major gains in efficiency and availability.



EMERGING DIRECTIONS AND RESEARCH NEEDS FOR FLOW NETWORK THERMAL-FLUID MODELING OF LIQUID COOLING SYSTEMS FOR AI FACTORIES

Alfonso Ortega
Villanova University

Abstract: This talk introduces flow network modeling (FNM) as a foundational approach for building predictive, control-oriented digital twins for next-generation AI thermal infrastructure, where GPU-driven systems span multiple scales from nano-scale circuits to rack-level architectures in emerging AI factories. While much attention has been placed on chip-level cooling, system-level design of single- and two-phase direct-to-chip liquid cooling is equally critical and increasingly dependent on high-fidelity digital twins that capture dynamic interactions among fluid flow, controls, and rapidly varying IT loads. FNM is particularly well suited for modeling transient behavior and evaluating control strategies, including determining controller sampling rates for aggressive load ramps, assessing rack-to-CDU transport delays, prioritizing rapid-response valves, and enabling smarter chiller staging based directly on IT load. Extending FNM to two-phase systems introduces additional challenges in flow distribution and transient stability, requiring advanced dynamic models of refrigerant behavior in components such as cold plates and condensers; these models enable comparison of control strategies to mitigate instabilities and optimize system response under rapidly changing thermal loads.

TT-05: EXTREME ENVIRONMENT ELECTRONICS

THURSDAY, MAY 28, 8:00 – 9:15 AM

LOWER LEVEL, AMARANTE 2-3



FERROELECTRIC AI PROCESSORS FOR EXTREME ENVIRONMENTS

Saidur Bakaul
RTX Technology Research Center

Abstract: Event-based imagers offer significant advantages over traditional frame-based cameras because they operate asynchronously, transmitting sparse data only when pixel-level changes occur. This characteristic inherently enables the low-latency capture of dynamic events. However, current system architectures often negate this benefit; data captured by sensors must be converted, transferred, and processed between the sensor and a remote AI accelerator, incurring significant latency and energy overhead. This long-standing bottleneck can be resolved by integrating CHIPLET-X directly near the sensor. CHIPLET-X is a dedicated AI processor built on various emerging device technologies, such as ferroelectric transistors (FeFETs), resistive RAM (ReRAM), and magnetic RAM (MRAM). By utilizing innovative algorithms and emerging memory-based architecture, this chip can achieve extreme efficiency. Its impact on the imager performance is particularly pronounced at extreme temperatures, where even minor fluctuations in efficiency can perturb the thermal landscape enough to induce exponential effects on target performance.



BEATING THE HEAT: DIAMOND AS AN ENABLER FOR HIGH-PERFORMANCE ADVANCED PACKAGE

Joana Catarina Martins Mendes
Telecommunications Institute

Abstract: As device power densities continue to rise in AI, HPC, and power electronics, thermal management has become one of the most pressing bottlenecks in advanced packaging. Diamond, with its unmatched thermal conductivity, high bandgap and radiation hardness, offers a unique pathway to

overcome these challenges. This talk will highlight recent advances in integrating synthetic diamond into advanced packaging — from heat spreaders and chip-carriers to on-die caps — enabling significant reductions in hotspot temperatures and improvements in energy efficiency. Potential applications will be discussed for both data centers, where cooling demands are escalating, and space electronics, where thermal reliability under extreme conditions is mission-critical.

TT-07: FUTURE OF HIGH-PERFORMANCE HEAT SINKS

THURSDAY, MAY 28, 2:00 – 3:30 PM

LOWER LEVEL, AMARANTE 2-3



NEXT-GENERATION THERMAL MANAGEMENT THROUGH TOPOLOGY OPTIMIZATION AND ADDITIVE MANUFACTURING

Xiaoping Qian
University of Wisconsin-Madison

Abstract: Escalating power densities in microelectronics, aerospace, and energy systems are pushing conventional heat sinks to their limits, motivating this research on the integration of Topology Optimization (TO) and Additive Manufacturing (AM) to create high-performance thermal management systems with complex, nontraditional geometries. TO provides a rigorous framework for optimally distributing material to minimize thermal resistance, enhance heat transfer, and balance fluid pressure losses, enabling advances across multiple cooling modalities. In liquid cooling, optimized designs reduce pumping power while eliminating hotspots; in air cooling, hierarchical fin structures improve convection in low-Re regimes; and for phase change materials, a novel co-optimization of enclosure geometry and conductive pathways enhances both energy storage and discharge rates. The work also extends to two-fluid heat exchangers, where simultaneous optimization of fluid domains and separating solids yields highly efficient counter-flow architectures. These designs are made manufacturable through high-resolution AM processes like Laser Powder Bed Fusion, with fabrication constraints embedded directly into the optimization, resulting in a streamlined pipeline from multiphysics design to practical, high-performance thermal hardware.



HIGH-PERFORMANCE CAPILLARY-BASED TWO-PHASE COOLING SOLUTION FOR ENERGY EFFICIENT DATA CENTERS

Mehdi Asheghi
Adjunct Professor
Stanford University

Abstract: Sustainable and efficient operation of US data centers requires transformative and innovative technologies. Nearly 20% of the total power is used to run the data center refrigeration cooling infrastructure, which is extremely sensitive to climate and environmental conditions. While increased public and private awareness in infrastructure operations of midsize and hyperscale data centers have resulted in improved cooling energy efficiency, the ever-increasing prevalence of higher-power processors and smaller edge data centers aggravate cooling/energy challenges. It is expected that reducing the thermal resistance of the device junction to coolant by 10 \times , will pave the way for elimination of refrigeration cooling system, resulting in considerable energy saving in the data centers.

We are leveraging an innovative capillary-based 3D-manifold for liquid delivery and vapor extraction, achieving nearly complete vapor-liquid phase separation, that results in a stable self-regulating two-phase cooling solution. We have already demonstrated (2 kW/GPU) capillary-based two-phase microcooler closed loop system with thermal resistance 0.01 K/W at 3 KW/server (COOLERSCHIPs performance target) using 70 °C water coolant. It is possible to achieve efficient cooling with power dissipation of 4 to 9 kW/GPU, thereby lifting the thermal limit for the next generation of GPUs.



THERMAL MANAGEMENT AS A PRODUCT ENABLER: HIGH-PERFORMANCE HEAT SINKS FOR ENERGY, ELECTRIFICATION, AND DATA CENTER SYSTEMS

William Dwight Gerstler
GE Vernova Advanced Research

Abstract: As power density increases across energy, industrial, and digital infrastructure systems, thermal management is becoming a key enabler of product performance rather than a downstream design constraint. In applications such as data centers, renewable energy conversion, and grid electrification, thermal limitations increasingly affect efficiency, reliability, switching capability, and system footprint. High-performance heat sinks offer a pathway forward through integrated thermal-packaging approaches, advanced fluids and phase-change cooling, and enhanced geometries such as topology-optimized structures and mini-/micro-channel designs. This talk examines the opportunities, design trade-offs, and implementation challenges associated with these technologies—including fluid selection, thermal-hydraulic performance, manufacturability, reliability, and cost—while highlighting their potential to unlock system-level gains in power density, size, weight, and cooling efficiency.

TT-09: LIQUID COOLING FOR DATA CENTERS

FRIDAY, MAY 29, 8:00 – 9:15 AM **LOWER LEVEL, AMARANTE 2-3**



LIQUID COOLING: HOW TO ACHIEVE 100% HEAT CAPTURE ON 500kW+ RACKS

Milad Samie
CoolIT Systems

Abstract: As rack power densities surge beyond 100 kilowatts (kW), achieving 100% heat capture becomes increasingly essential for thermal management and operational efficiency. Current coldplate designs focus on high-thermal design power components such as CPUs and GPUs, but future architectures demand complete heat removal across all components. Even at 90% heat capture, a 500kW rack leaves 50kW for air cooling, which is a stretch for even the best air-cooled implementations. Enabling 100% heat capture will be critical for supporting next-generation AI infrastructure. Join us to learn how integrated cooling loops and advanced coldplate technologies enable complete heat removal across the entire server.



OPPORTUNITIES AND CHALLENGES OF DIRECT TO CHIP LIQUID COOLING

Berhanu Wondimu
Intel

Abstract: Rising power demands from High Performance Computing (HPC) and Artificial Intelligence (AI) are intensifying thermal management challenges in modern data centers, making the transition from air to liquid cooling increasingly necessary for high Thermal Design Power (TDP) systems. Direct-to-Chip (DTC) cold plate technology has emerged as a leading solution, but its widespread adoption is constrained by practical challenges such as coolant leaks, material compatibility, corrosion, and fluid quality monitoring. This talk will explore both the opportunities and barriers associated with DTC liquid cooling, drawing on industry experience to highlight key lessons learned and the path toward safe, reliable, and scalable deployment.

Over a decade
delivering fanless
designs.

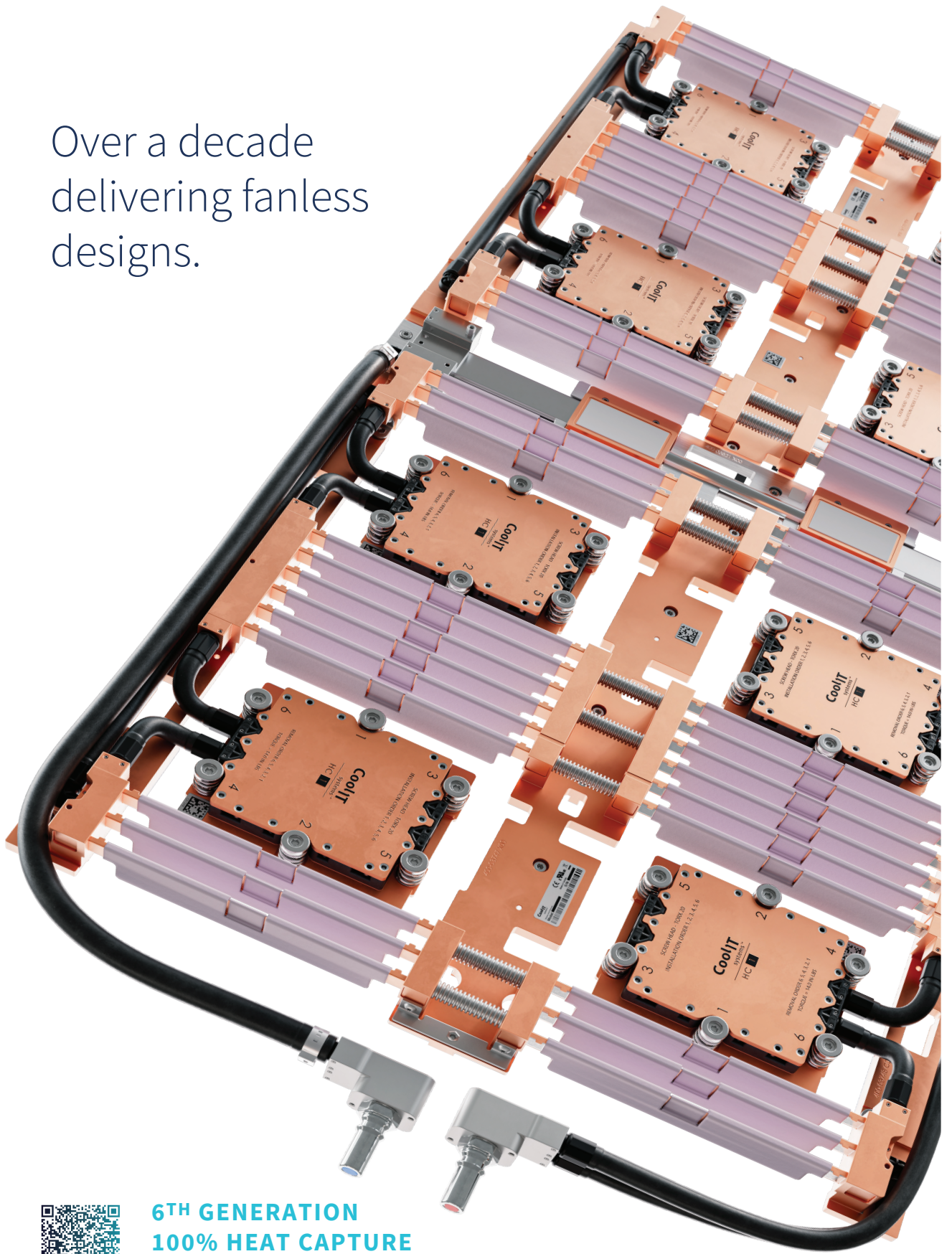

**6TH GENERATION
100% HEAT CAPTURE
SUPERCOMPUTER BLADE**

CoolIT
systems™

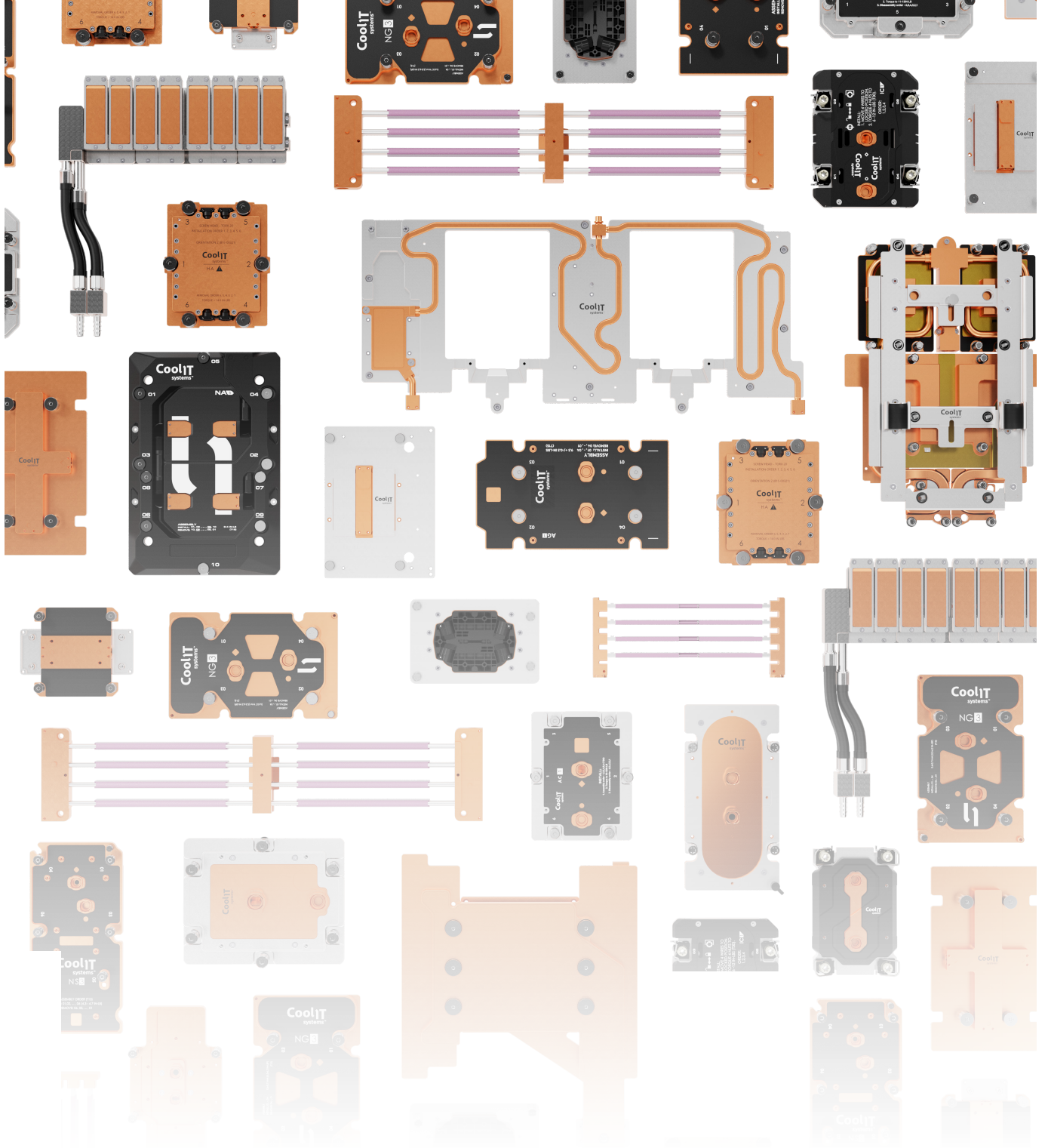

Achieve 100% heat capture with a complete portfolio of coldplates.

CoolIT
systems™

PANEL SESSIONS

SPONSORED BY:



P-02: POWERING THE FUTURE OF HPC: LIQUID COOLING AND DATA CENTER INNOVATION

WEDNESDAY, MAY 27, 11:00 AM – 12:30 PM

LOWER LEVEL, AMARANTE 2-3

MODERATOR ABSTRACT



**Dr. Raffaele
Luca Amalfi**
SEGUENTE

Data processing, transport, and storage demands are increasing exponentially, driven by applications in mobile broadband, video/gaming, cloud computing, 5G networks, artificial intelligence, and the Internet of Things. These trends are directly linked to next-generation digital transformation, characterized by intelligent machine-to-machine and human-to-machine communications that enable “everything everywhere” automation within a new ecosystem. This evolution has profound implications for system design, requiring greater functionality per unit volume and resulting in higher heat densities. Consequently, thermal management, particularly through liquid cooling—will be critical in addressing the growing sustainability and performance challenges faced by large-scale computing and telecommunications systems, which are rapidly integrating digital technologies into nearly every aspect of society.

PANELISTS



Fillipo Cataldo
Weiland



Pritish Parida
IBM



Ryna Enright
SEGUENTE



Baris Dogruoz
Microsoft



Peter de Bock
Eaton



Darin Sharar
TauMat

P-04: THERMAL AND MECHANICAL CHALLENGES AND OPPORTUNITIES IN ADVANCED MOBILE, AI, AUTOMOTIVE, SPACE, AND HIGH-POWER-DENSITY COMPUTING DEVICES

WEDNESDAY, MAY 27, 4:00 – 5:30 PM

LOWER LEVEL, AMARANTE 2-3

MODERATOR ABSTRACT



Dr. Victor Chiriac
Global Cooling
Technology Group

The digital world requires higher performance, more data and faster processors. The demand for higher performance, faster processors, and increased data capacity drives advancements in heterogeneous computing. This includes CPUs, GPUs, and high-speed interconnects, among other elements. The rise of 5G/6G, AI and IoT applications has enabled innovations in Smart Cities, autonomous vehicles, AR/VR, AI robotics, and digital healthcare. This panel will share their vision and will discuss the future of small to large electronics thermal management and other advanced component and system level thermo-mechanical challenges, as well as technical and business solutions.

PANELISTS



Sam Graham
University of Maryland



Rozalia Beica
Rapidus, USA



Amy Marconnet
Purdue University



Yogendra Joshi
DARPA



Ross Wilcoxon
Collins Aerospace



Russell Kempt
Diamond Foundries Inc., USA



Michael Ohadi
University of Maryland

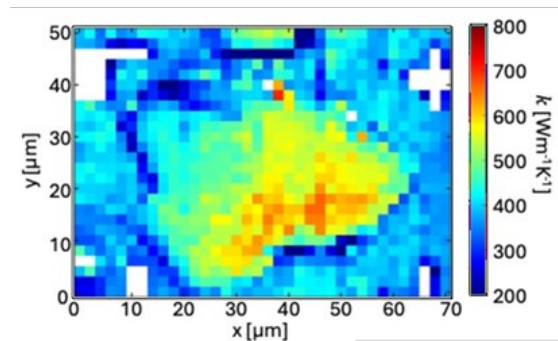

Diamond in the Rough
Mehdi Ashegi

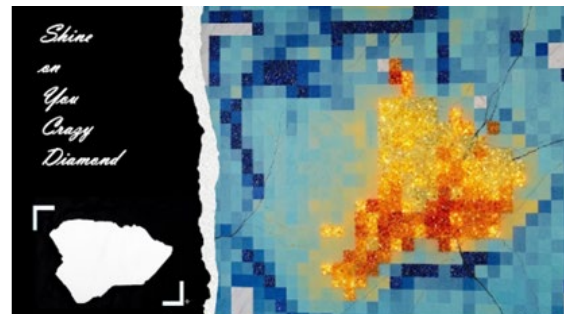

Shine on you Crazy Diamond
Luke Min

P-06: ADVANCED MANUFACTURING: ENABLING THE FUTURE OF ELECTRONICS THERMAL MANAGEMENT

THURSDAY, MAY 28, 11:00 AM – 12:30 PM

LOWER LEVEL, AMARANTE 2-3

MODERATORS



Alfonso Ortega
Villanova
University



Arun Muley
Boeing

ABSTRACT

Traditionally, the design of electronic packaging, cold plates, and related thermal management components has been constrained by manufacturing limitations, with solutions dictated more by what could be fabricated than by what performance demanded. Recent advances in design methodologies, including topology optimization, combined with high-fidelity additive and subtractive manufacturing in silicon, ceramics, and metals, are shifting this paradigm. These capabilities enable increasingly integrated, high-performance thermal solutions. This panel will examine the current state of the art in these approaches and assess the performance gains achievable in cooling modern high-power electronic systems.

PANELISTS



Srdan Vasic
Exentis AG

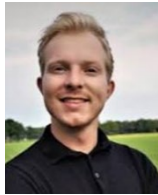

Remco van Erp
Corintis



Brad (Nan) Chen
Aegis Technologies



Kumar Singh
Intel Foundries

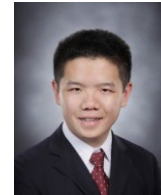

Zheng Liu
University of
Michigan-Dearborn

P-08: ADVANCED MECHANICS AND RELIABILITY

THURSDAY, MAY 28, 4:00 PM – 5:30 PM

LOWER LEVEL, AMARANTE 2-3

MODERATORS



**Ross
Wilcoxon**
Collins
Aerospace



**Patrick
McCluskey**
University of
Maryland

ABSTRACT

This Panel will include experts from industry and academia, to discuss the emerging needs for reliability and deviations from legacy requirements and methodologies. Application spaces include aerospace, vehicles, and datacenter/AI operations, power electronics, materials. The panel members will discuss examples of where existing accelerated testing standards fall short and where specific electronics applications and environmental demand improved qualification methods to meet requirements for mission critical functions.

PANELISTS



Bongtae Han
University of Maryland

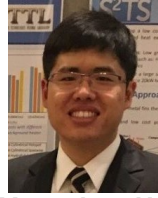

Yuanchen Hu
Lightmatter



Joshua Pennington
Henkel



Gamal Refai-Ahmed
AMD



Pranay Nagrani
IBM Corp.



David Huitink University of
Arkansas

P-10: COOLING FOR AI AND AI FOR COOLING – CHALLENGES AND APPLICATIONS

FRIDAY, MAY 29, 11:00 AM – 12:30 PM

LOWER LEVEL, AMARANTE 2-3

MODERATORS



Remco van Erp
Corintis



Damena Agonafer
UMD

ABSTRACT

This panel will dive into the relationship between artificial intelligence and thermal management. We will discuss the increasing cooling requirements driven by AI-hardware and high-density data centers, alongside the role of AI in optimizing cooling system design and operation. The session aims to provide a comprehensive look at how the industry is addressing rising heat loads while utilizing machine learning to improve efficiency.

PANELISTS



Ryan Enright
SEGUENTE



Michael Ohadi
University of Maryland



Chirag R. Kharangate
Case Western



Sung-Ki Kim
Intel



Yoonjin Won
UC Irvine



Ravi Bharath
Celestica

ITHERM 2026 AVRAM BAR-COHEN BEST PAPER AWARD NOMINEES

COMPONENT-LEVEL THERMAL MANAGEMENT

High-Fidelity Reduced-Physics Modeling of Two-Phase Flow Through Counter-Flow Expanding Channels Cold-Plate

Pritish Paridai¹, Mark Schultz¹, & Timothy Chanier¹

¹IBM Research

Enhancing Two-phase Direct Liquid Jet-Impingement Cooling with Etched and Laser-Ablated Pin-Fins for 2.5D Semiconductor Packages

Insik Lee¹, Sangha Baek¹, Seungwoo Kim¹, Jaechoon Kim², Youngsuk Nam¹

¹KAIST, ²Samsung Electronics

Evaluation of Flow and Heat Transfer in Morphologically Blended Porous Unit Cells for Advanced Heat Exchangers with Functionally Graded Designs

Jaewon Park¹, Justin Weibel¹, Davide Ziviani¹

¹Purdue University

Applying Cumulative Structure Functions to Quantify Latent Thermal Buffering in Phase Change Composites

Lucas Oelkers¹, Rachel McAfee², Soonwook Kim¹, Adam Wilson², Michael Fish³, Patrick Shamberger¹

¹Texas A&M University, ²U.S. DEVCOM Army Research Laboratory, ³CCDC Army Research Laboratory

Altering Filmwise Flow Condensation Behavior of Wetting Fluids via 3D-printed Wick Structures

Durga Ghosh¹, Jebin Joshua Isaac Raj¹, Vivek Mano Mohan¹, Mohammad Reza Shaeri², Sajjad Bigham¹

¹North Carolina State University, ²Advanced Cooling Technologies, Inc.

Thermal Floorplanning and Package Co-Optimization for Monolithic 2D ICs

Ashwin Kidambi¹, Justin Weibel¹, Liang Pan¹

¹Purdue University

Microfabrication of Large-area (3 cm × 3 cm) Si-based Microchannel Manifold Cooler for Heterogeneous Integrated Microsystem

Heungdong Kwon¹, Luke Min¹, Daeyoung Kong¹, Mehdi Asheghi¹, Kenneth Goodson¹

¹Stanford University

SYSTEM-LEVEL THERMAL MANAGEMENT

Towards 1 MW Data Center Racks: System-Level Modeling of a Membrane-Assisted Two-Phase Cooling Architecture

Roshith Mittakolu¹, Ibaad Gandikota¹, Damena Agonafer¹, Patrick McCluskey¹, Saeed Moghaddam²

¹University of Maryland at College Park, ²University of Florida

Automated Electro-Thermal Modeling Framework of Distributed Vertical Power Delivery Long-Term Reliability and Stability Analysis of Single-Phase Immersion Cooling for Datacenter Applications

Yuehong Fan¹, Wenbin Tian¹, Nishi Ahuja², Jianwu Zheng³, Xiangwu Chen³, Bing Cheng³, Xiaojin Fan³, Yong Sheng³, Yongzhan He³

¹Intel Asia Pacific R&D Ltd., ²Intel Corporation, ³Baidu

Shallow Pool Boiling of Novec 649 on Planar/Finned Copper Inverse Opal (CuOs) Structures

Hongchi Liu¹, Kaiying Jiang¹, Daeyoung Kong¹, Yujui Lin¹, Heungdong Kwon¹, Mehdi Asheghi¹, Kenneth Goodson¹

¹Stanford University, ²Seguente, ³Purdue University

MECHANICS AND RELIABILITY

Mechanical Properties and Microstructural Evolution in SAC-LTS Hybrid Solders with Varying Bi Concentrations Subjected to Aging

Mahbub Alam Maruf¹, Souvik Chakraborty¹, Jeffrey Suhling¹, Pradeep Lall¹

¹Auburn University

Thermo-Mechanical Characterization of Molded and Unmolded Substrates under Single-Phase Immersion Cooling

Rohit Suthar¹, Sonkolon Barua¹, Dikshya Bhattarai¹, Unique Rahangdale¹, Megha Tangri¹, Ivneet Banga¹, Yogesh Fulpagare¹, Dereje Agonafer¹, Karthekeyan Sridhar², Blake Travis², Rajen Murugan², Lalith Karsani², Osvaldo Lopez²

¹The University of Texas at Arlington, ²Texas Instruments

Evaluation of Board-Level Drop Test Reliability of Flexible In-Mold Electronics under after Isothermal Exposure

Aathi Raja Ram Pandurangan¹, Md Golam Sarwar¹, Pradeep Lall¹ & Scott Miller²

¹Auburn University, ²NextFlex

Design of a Metrology Tool to Evaluate Degradation of Thermal Greases with Dynamic Warpage

Sabina Bimali¹, Ritwik Kulkarni¹, Amy Marconnet¹

¹Purdue University

EMERGING TECHNOLOGIES AND FUNDAMENTALS

Investigating Thermal Runaway and Gas Venting in 18650 Lithium-Ion Cell: A Case Study Using ANSYS Fluent In-Built Battery Module

Jiajun Xu¹, Justin An¹, Aigbe Awenlimobor¹

¹University of the District of Columbia

High-Speed Visualization of Flow Boiling Inversion and Hysteresis using Self-Organized Laser Functionalization (SOLF) of Stainless Steel Surfaces in Water

Logan Pettit¹, Graham Kaufman¹, Josh Gerdes¹, Andrew Reicks¹, Craig Zuhlke¹, George Gogos¹

¹University of Nebraska-Lincoln

Transistor Level, Geometry-Driven Thermal Management in FinFET and FDSOI Technology

Lisa Tondelli¹, Bjorn Vermeersch², Luca Selmi¹, Herman Oprins²

¹Università degli Studi di Modena e Reggio Emilia, ²imec

A Simplified Shift-Left Methodology for Early Thermal Analysis of Heterogeneously Integrated Chip-Package System

Aakrati Jain¹, Sujyesh Aanandh Manjunathan², Lee Johnson¹, Christine Bui¹, Don Labreque¹, Akif Ali¹, Cheng Chi¹

¹IBM, ²Synopsys, Inc

DeepONet-Enabled Fast and Scenario-Aware Spatial Temperature Prediction of a Vertical Power Delivery Module for Hyperscale Data Centers

Mingeun Choi¹, Michael Herndon², Kawika Uechi², Nabil Ake², Satish Kumar¹,

¹Georgia Institute of Technology, ²Claros, Inc.

Natural Convection Heat Sink Design via Conjugate Simulations and Simplified Topology Optimization

Yanbo Huang¹, Michel Romero², Hunter Watts, Justin Weibel¹

¹Purdue University, ²Schneider Electric, ³Sc

DATA CENTERS

Experimental investigation of R1234ze(E) condensation in liquid-cooled brazed plate heat exchangers for pumped two-phase data center cooling applications

Pranay Nagrani¹, Brian Werneke¹, Milnes David¹, Pritish Parida², Carol Caceres¹, Timothy Chainer²

¹IBM Corporation, ²IBM Research

Machine Learning Guided Cooling Optimization for Data Centers

Shrenik Jadhav¹, Zheng Liu¹

¹University of Michigan-Dearborn

A Multi-Resolution Anomaly-Detection Framework for Near-Exascale HPC Systems

Mohan Kumar Gajendran¹, Ijaz Fazil Syed Ahmed Kabir², Ng Yin Kwee Eddie²

¹UMKC, ²Nanyang Technological University, ³Purdue University



EXPANDING ACCESS OF
LIQUID METAL THERMAL INTERFACE
MATERIALS IN PERSONAL COMPUTING,
MOBILE DEVICES AND DATA CENTER
APPLICATIONS



LairdTM

Arieica Inc., and Laird Technologies Inc.
have entered into a licensing agreement to enable the evaluation and commercialization of
Arieica's breakthrough Liquid Metal Embedded Elastomer (LMEE) innovation
in personal computers, mobile devices and data centers applications,
supported by Laird's established testing platforms, strong technical sales expertise, and global
commercial infrastructure.

CONFERENCE TECHNICAL PROGRAM

TRACKS & SESSIONS

COMPONENT-LEVEL THERMAL MANAGEMENT

- CT-01A Microgaps and Embedded Cooling
- CT-01B Heat Spreaders
- CT-02 RF and Power Electronics
- CT-03 Additive Manufacturing and Topology Optimization
- CT-04 Vapor Chambers and Thermosyphons
- CT-05 Advanced Packaging/Hi Thermal Management
- CT-06A Single-Phase Cold Plates – Modeling
- CT-06B Hotspot Mitigation
- CT-07A Two-Phase Cold Plates – Experimental
- CT-07B Thermal Interface Materials
- CT-08 Two-Phase Cold Plates – Modeling
- CT-09 Impingement Cooling
- CT-10 Single-Phase Cold Plates - Experimental

EMERGING TECHNOLOGIES & FUNDAMENTALS

- EF-01 Two-Phase Heat Transfer: Pool Boiling
- EF-02 Two-Phase Heat Transfer: Flow Boiling and Microstructures
- EF-03 Boiling Surface Enhancements
- EF-04 Topology Optimization, Design Automation
- EF-05 Topology Optimization, Two-Phase
- EF-06 Physics-Informed Machine Learning and Predictive Analytics
- EF-07 AI Application for Thermal Optimization
- EF-08 Thermal Diagnostics, Metrology & Experimental Methods
- EF-09 Nanoscale and Transistor-Level Thermal Transport
- EF-10 Thermal Characterization or Advanced Materials

SYSTEM-LEVEL THERMAL MANAGEMENT

- ST-01 Air Cooling Methods and Compact Air-Side Thermal Design
- ST-03 Automotive, Batteries, and Thermal Storage
- ST-05 Liquid Cooling Solutions and System Integration
- ST-07 Single-Phase Immersion Cooling
- ST-09 Transient Thermal Management, Controls, and Emerging Applications
- ST-10 Two-Phase Cooling and Flow Control

DATA CENTERS



- DC-02 AI/ML Techniques for Power and Thermal Modeling in Data Centers
- DC-04 Liquid Cooling Methods in Data Center Applications
- DC-06 Air Cooling Methods for Data Centers
- DC-08 Reliability, Sustainability, Economics, and Scaling for Data Centers
- DC-10 Hybrid and Novel Cooling Methods for Data Centers

MECHANICS & RELIABILITY

- MR-02 Solder Joints - I
- MR-03 Advanced Packaging and Hybrid Bonding
- MR-04 Reliability of Liquid Cooling Techniques
- MR-05 Material Characterization
- MR-08 Thermo-Mechanical Modeling
- MR-09 Solder Joints II

TRACK SPONSORSHIP BY



DAY 1: WEDNESDAY, MAY 27						
7:00 AM	Breakfast					<i>Palazzo E-H</i>
8:00 AM	CT-01A Microgaps and Embedded Cooling <i>Del Lago 1-2</i>	ST-01 Air Cooling Methods and Compact Air-Side Thermal Design <i>Del Lago 3-4</i>	EF-01 Two-Phase Heat Transfer: Pool Boiling <i>Segura 5</i>	CT-01B Heat Spreaders <i>Segura 6</i>	TT-01 Thermal Packaging in Aviation/Space Defense Systems <i>Amarante 2-3</i>	
9:15 AM	Break					
9:30 AM		Keynote K-1: Frontiers of Quantum Computing Infrastructure Sean Hart Research Scientist, IBM Research			<i>Segura 1-4</i>	
10:30 AM	Coffee Break					<i>Palazzo E-H</i>
11:00 AM	CT-02 RF and Power Electronics <i>Del Lago 1-2</i>	DC-02 AI/ML Techniques for Power and Thermal Modeling in Data Centers <i>Del Lago 3-4</i>	E-02 Two-Phase Heat Transfer: Flow Boiling and Microstructures <i>Segura 5</i>	MR-02 Solder Joints - I <i>Segura 6</i>	P-02 Powering the Future of HPC: Liquid Cooling and Data Center Innovation <i>Amarante 2-3</i>	
12:30 PM		Luncheon: Richard Chu Award Talk Materials, Process, and Metrology: Innovating Thermal Management Solutions at the Die Level Sam Graham Dean, Clark School of Engineering, University of Maryland			<i>Palazzo E-H</i>	
2:00 PM	CT-03 Additive Manufacturing and Topology Optimization <i>Del Lago 1-2</i>	ST-03 Automotive, Batteries, and Thermal Storage <i>Del Lago 3-4</i>	EF-03 Boiling Surface Enhancements <i>Segura 5</i>	MR-03 Advanced Packaging and Hybrid Bonding <i>Segura 6</i>	TT-03 Advances in Data Center Cooling and Intelligent Thermal Control <i>Amarante 2-3</i>	
3:30 PM	Coffee Break					<i>Del Lago Prefunction</i>
4:00 PM	CT-04 Vapor Chambers and Thermosyphon <i>Del Lago 1-2</i>	DC-04 Liquid Cooling Methods in Data Center Applications <i>Del Lago 3-4</i>	EF-04 Topology Optimization, Design Automation <i>Segura 5</i>	MR-04 Reliability of Liquid Cooling Technologies <i>Segura 6</i>	P-04 Thermal and Mechanical Challenges and Opportunities in Advanced Mobile, AI, Automotive, Space, and High-Power-Density Computing Devices <i>Amarante 2-3</i>	
5:30 PM	Student Heat Sink Design Challenge					<i>Segura 1-4</i>
7:00 PM	ASME K-16 & Journal of Electronic Packaging Meeting					<i>Segura 6</i>

Day 1: Wednesday, May 27th 8:00 AM–9:15 AM

TT-01 Thermal Packaging in Aviation/Space Defense Systems

AMARANTE 2-3 Chairs: *Shantonio Birch (ThermoVerse) and Georges Pavlidis (University of Connecticut)*

Clayton Pullins

Advanced Packaging for Efficient Microelectronics Thermal Management

Edward Horne

Microfluidic Cooling Integrated Into Glass Substrates

CT-01A Microgaps and Embedded Cooling

DEL LAGO 1-2 Chairs: *Durga Ghosh (North Carolina State University) and Mark Schultz (IBM)*

- 8:00 AM (#66) Design and Microfabrication of a Large Area Silicon Manifold Microchannel Heat Sink for High Heat Flux Cooling Applications;** Tahir Mahmud¹, Kyle J. Martin¹, Andres Sarmiento¹, Michael Ohadi¹; ¹*University of Maryland at College Park*
- 8:15 AM (#302) Numerical Analysis of Enhanced Cooling Performance of a Manifold Microchannel Heat Sink;** Jarred Wilhite¹, Chirag Kharangate¹; ¹*Case Western Reserve University*
- 8:30 AM (#357) Interconnect-Level Liquid Cooling in Dielectric Layer-Coated Microbump for High Heat Flux Advanced Packaging;** Daeyoung Kong¹, Jiho Joo², Sunghwan Han¹, Jinyoung Kim¹, Jiwon Im¹, Taegy Kim¹, Junggho Shin², Gwang-Mun Choi², Seok-Hwan Moon², Yong-Sung Eom², Kwang-Seong Choi², Yunhyeok Im¹; ¹*KoolMicro, Inc.*, ²*Electronics and Telecommunications Research Institute*
- 8:45 AM (#417) Microfabrication of Large-Area (3 Cm × 3 Cm) Si-Based Microchannel With 3D Manifold Cooler for Heterogeneous Integrated Microsystems;** Heungdong Kwon¹, Luke G. Min², Daeyoung Kong³, Christina Seeholzer⁴, Christopher S. Roper⁴, Mehdi Asheghi², Kenneth Goodson²; ¹*Kyung Hee University*, ²*Stanford University*, ³*KoolMicro, Inc.*, ⁴*HRL Laboratories, LLC*
- 9:00 AM (#420) Impact of Additive Manufacturing Defects and Post-Processing Imperfections on the Performance of an Optimized Supercritical CO Heat Exchangers;** Namir M. Bruck¹, Zhengda Yao¹, Amir Shoostari¹; ¹*University of Maryland at College Park*

ST-01 Air Cooling Methods and Compact Air-Side Thermal Design

DEL LAGO 3-4 Chairs: *Nathan Van Velson (Advanced Cooling Technologies, Inc.) and Anil (Neil) Yuksel (Ecolab)*

- 8:00 AM (#457) Zoned Cooling: An Innovative Laptop Design Strategy Enabled by Ionic Air Movement;** Brian Cumpston¹, Mark MacDonald¹, Himanshu Pokharna²; ¹*Ventiva, Inc.*, ²*Deep Materials*
- 8:15 AM (#22) Miniaturization of Fin Volume for Radio Unit Housings;** Akira Kon¹, Yoji Ohashi², Yoshihiro Nakata²; ¹*Finity, 21 Finity*
- 8:30 AM Sponsored Talk;** David Garcia
(Sponsored)
- 9:00 AM (#316) Artificial Neural Network-Based Prediction of Satellite Orifice Orientation Effects on Synthetic Jet Performance;** Faisal Ahmed¹, Mehmet Arik¹; ¹*Auburn University*
- 9:15 AM (#278) Enhancing Equipment Longevity in Polluted Environments: A Closed-Loop Air-to-Air Heat Exchanger Approach;** Mohammed Ghouse¹, Neeraj Singh¹, Robert R. William¹, Manigandan Boopalan¹, Prashanth Pavithran¹; ¹*Cisco Systems*

EF-01 Two-Phase Heat Transfer: Pool Boiling

SEGURA 5 Chairs: *David Coenen (imec) and Steven Verhaverbeke*

- 8:00 AM** **Thermal Network Analysis of a Boiling Chamber With Enhanced Evaporators and Condensers in a Novel 1U Boiling Chamber**; Nooruldeen E. Mustafa¹, Satish Kandlikar¹; ¹*Rochester Institute of Technology*
(#36)
- 8:15 AM** **Effects of Heater Size and Spacing on Pool Boiling Characteristics in Multichip Modules**; Suhan Kim¹, Yunseo Kim², Youngseob Lee¹, Daeyoung Kong³, Seonghyuk Lee¹, Hyoungsoon Lee¹; ¹*Chung-Ang University*, ²*University of Maryland at College Park*, ³*KoolMicro, Inc.*
(#50)
- 8:30 AM** **Coupled Effects of Subatmospheric Pressure and Surface Structures on Pool Boiling**; Mohammad Ishraq Hossain¹, Christy Dunlap¹, Annapurna Parjuli¹, Han Hu¹; ¹*University of Arkansas*
(#142)
- 8:45 AM** **Engineering Hierarchical Micro-Structured Copper Surfaces via Conventional Milling for Pool Boiling Enhancement**; Merve Baykal¹, Michael Guerrero¹, Farzad R. Talabazar¹, Mustafa Ozsipahi², Ashish Gandhi¹, Jung-Chih Chiao¹, Ali Beskok¹; ¹*Southern Methodist University*, ²*U.S. DEVCOM Army Research Laboratory*
(#246)
- 9:00 AM** **Engineering Nucleation Cavity Size and Spacing for Pool Boiling Enhancement**; Wonhee Cho¹, Takiyah Ali¹, Shuai Che¹, Mitchell Whiting², Ilya T'Jollyn², Tomasz Kulakowski¹, Solomon Adera¹; ¹*University of Michigan*, ²*University of Antwerp*
(#436)

CT-01B Heat Spreaders

SEGURA 6 Chairs: *Dhruv Kumar Shah (Cisco Systems) and Onur Yenigun (imec)*

- 8:00 AM** **Thermal Conductivity Mapping of Diamond-Copper Composite Using Scanning TDTR Microscopy**; Luke G. Min¹, Heungdong Kwon², Christina Seeholzer³, Christopher S. Roper³, Mehdi Asheghi¹, Kenneth Goodson¹; ¹*Stanford University*, ²*Kyung Hee University*, ³*HRL Laboratories, LLC*
(#37)
- 8:15 AM** **Enhanced Thermal Spreading in 3d-Printed Titanium Tube-Fin Assembly With Embedded Pyrolytic Graphite**; Braden Stevens¹, Daniel V. Curl¹, Chinmaya Joshi², Aishwarya Rath¹, Ying Sun³, Han Hu¹; ¹*University of Arkansas*, ²*University of Colorado, Boulder*, ³*University of North Carolina at Charlotte*
(#97)
- 8:30 AM** **Applying Cumulative Structure Functions to Quantify Latent Thermal Buffering in Phase Change Composites**; Lucas Oelkers¹, Soonwook Kim¹, Rachel McAfee², Adam Wilson², Michael Fish², Patrick Shamberger¹; ¹*Texas A&M University*, ²*U.S. DEVCOM Army Research Laboratory*
(#276)
- 8:45 AM** **Transient Cooling of GaN-based Transistors Using Phase Change Material**; Shuyi Zhang¹, Biruk Teka Gidreta¹, Elikem J. Amegah¹, Al-Thaddeus Avestruz¹, Solomon Adera¹; ¹*University of Michigan*
(#311)
- 9:00 AM** **Enhancing Capillary-Driven Evaporator Performance by Engineering Pin Fin Wick Permeability in Three Dimensions**; Matthew Coughlin¹, Yujui Lin¹, Mehdi Asheghi¹, Kenneth Goodson¹; ¹*Stanford University*
(#423)

Day 1: Wednesday, May 27th 11:00 AM–12:30 PM

P-02 Powering the Future of HPC: Liquid Cooling and Data Center Innovation

AMARANTE 2-3 Chairs: *Raffaele Luca Amalfi* Panelists: *Filippo Cataldo (Wieland)*, *Peter de Bock (Eaton)*, *Baris Dogruoz (Microsoft)*, *Ryan Enright (Seguente)*, *Pritish Parida (IBM Research)* and *Darin Sharar (TauMat)*

CT-02 RF and Power Electronics

DEL LAGO 1-2 Chairs: *David Huitink (University of Arkansas)* and *Ross Wilcoxon (Collins Aerospace)*

- 11:00 AM (#1) Ultra-Wide Bandgap AlGaN-channel High Electron Mobility Transistors With High Thermal Performance;** Seokjun Kim¹, Eungkyun Kim², Jimy Encomendero², Debdeep Jena², Huili Grace Xing², Sukwon Choi¹; ¹*Pennsylvania State University*, ²*Cornell University*
- 11:15 AM (#70) Mitigating Self-Heating in GaN HEMTs Using a High Resistivity Drain-Connected Field Plate;** Daniel C. Shoemaker¹, Tae Kyoung Kim², Moon Uk Cho², Minji Kim³, Jiun Oh³, Joon Seop Kwak³, Sukwon Choi¹; ¹*Pennsylvania State University*, ²*Wavelord*, ³*Korea Institute of Energy Technology*
- 11:30 AM (#126) Thermal-Hydraulic Performance Analysis of Dual-Service Cold Plate for EV Power Electronics;** Akin Chakma¹, Himel Barua², Amitav Tikadar¹; ¹*University of Mississippi*, ²*Oak Ridge National Laboratory*
- 11:45 AM (#286) Impact of Die Substrate Properties on Peak Temperature of AlGaN HEMTs via Package-Level Simulation;** Francis D. Vasquez¹, John D. Morris², Chandan Joishi², Xioawei Cai², James G. Fiorenza², Georges Pavlidis¹; ¹*University of Connecticut*, ²*Analog Devices Inc.*
- 12:00 PM (#406) Ultra-Low Thermal Resistance GaN-in-Diamond HEMT Technology;** James Spencer Lundh¹, Tatyana Feygelson², Francis D. Vasquez³, Ethan Scott⁴, Alan Jacobs¹, Andrew Koehler², B. Pate¹, Karl Hobart¹, Travis Anderson⁵, Michael Mastro¹, Patrick Hopkins⁴, Georges Pavlidis³, Daniel Francis⁶, Marko Tadjer²; ¹*NRL*, ²*U.S. Naval Research Laboratory*, ³*University of Connecticut*, ⁴*University of Virginia*, ⁵*University of Florida*, ⁶*Akash Systems*
- 12:15 PM (#428) Simulation of Hot Spot Temperature in GaN Devices: Impacts of Non-Fourier Effects;** Tanvirul Abedien¹, Qihao Xu¹, Tianli Feng¹; ¹*University of Utah*

DC-02 AI/ML Techniques for Power and Thermal Modeling in Data Centers

DEL LAGO 3-4 Chairs: *Chirag Kharangate (Case Western Reserve University)* and *Gargi Kalikhura (Arista)*

- 11:00 AM (#341) Physics-Informed Neural Networks for Control Volume Modeling of Flow Condensation;** Sudharsun Govindaraj¹, Jayachandran K. Narayanan¹, Farshad B. Golezani¹, Chirag Kharangate¹; ¹*Case Western Reserve University*
- 11:00 AM (#415) A Multi-Resolution Anomaly-Detection Framework for Near-Exascale HPC Systems;** Mohan Kumar Gajendran¹, Ijaz Fazil Syed Ahmed Kabir², Ng Yin Kwee Eddie²; ¹*University of Missouri-Kansas City*, ²*Nanyang Technological University*
- 11:00 AM (#141) Machine Learning Guided Cooling System Optimization for Data Center;** Shrenik A. Jadhav¹, Zheng Liu¹; ¹*University of Michigan-Dearborn*
- 11:00 AM (#343) Data-Driven Identification of Lee Coefficient Distributions in Horizontal Channel Flow Boiling Using Inverse PINNs;** Sudharsun Govindaraj¹, Jayachandran K. Narayanan¹, Partha Pratim Roy², Satish Kumar², Chirag Kharangate¹; ¹*Case Western Reserve University*, ²*Georgia Institute of Technology*
- 11:00 AM (#300) A Physics-Informed Reinforcement Learning Framework for Economic-Thermal Co-Optimization of Crypto Mining Data Centers;** Viswanathan Ganesh¹, Hongjun Li¹, Jiyuan Sui¹, Wangda Zuo¹; ¹*Pennsylvania State University*
- 11:00 AM (#348) Machine Learning- Assisted Prediction of Heat Sink Performance in Single-Phase Immersion Cooling;** Meysam Emami¹, Megha Tangri¹, Rohit K. Suthar¹, Unique Rahangdale¹, Prasanna Jayaramu¹, Dereje Agonafer¹, Mei Yang¹; ¹*The University of Texas at Arlington*

EF-02 Two-Phase Heat Transfer: Flow Boiling and Microstructures

SEGURA 5 Chairs: Carlos Da Silva (University of Toronto) and Sunilkumar Pinnu (AMD)

- 11:00 AM** (#24) **Transient Characterization of Local Heat Transfer in a Silicon Microchannel Under Pressure Drop Oscillation;** Taeil Kim¹, UngJin Na¹, Gyudong Lee¹, HangJin Jo¹; ¹*Pohang Science and Technology University*
- 11:15 AM** (#38) **Exploring the Physics of Capillary Boiling and Bubble Dynamics in Hierarchical Silicon Wicks Using Coupled Thermal Imaging and High-Speed Flow Visualization;** Yujui Lin¹, Heungdong Kwon², Kewei Xiao³, Man Prakash Gupta³, Michael Degner³, Mehdi Asheghi¹, Kenneth Goodson¹; ¹*Stanford University*, ²*Kyung Hee University*, ³*Ford Motor Company*
- 11:30 AM** (#57) **Enhancing Liquid Cooling Through Viscoelastic Instabilities: A Strategic Approach to Flow Geometry Design;** Tamal Roy; *University of Nebraska-Lincoln*
- 11:45 AM** (#240) **Computational Analysis of Flow Boiling With Immiscible Liquid Combinations in Mini-Channels;** Bhavin Yardi¹, Max Pawlick¹, Satish Kumar¹; ¹*Georgia Institute of Technology*
- 12:00 PM** (#329) **Enhancing Flow Boiling Enhancement in a Diverging Microchannel With Microscale Roughness;** Sayan Karmakar¹, Constantine Megaridis¹; ¹*University of Illinois, Chicago*
- 12:15 PM** (#358) **Acoustically Enhanced Subcooled Boiling for Electronics Thermal Management;** Daeryun Choi¹, Young Jin Lee¹, Solomon Adera¹; ¹*University of Michigan*

MR-02 Solder Joints - I

SEGURA 6 Chairs: Golam Rakib Mazumder (Auburn University) and Ganesh Subbarayan (Purdue University)

- 11:00 AM** (#12) **Impact of Short-Term Aging on the Mechanical Shock Reliability of SAC305 Solder Joints;** Saddam Daradkeh¹, Abdallah H. Alakayleh¹, Sufyan Tahat¹, Waad Tarman¹, Sergio Bolanos¹, Yanal Masarweh¹, Elizabeth P. Gainey¹, Omar Alhussien¹, Jeffrey Suhling¹, George Flowers¹, Sa'd Hamasha²; ¹*Auburn University*, ²*Binghamton University*
- 11:15 AM** (#13) **Thermal Cycling Effects on Hardness of SAC-Bi Solder Joints With Different Paste-to-Ball Ratios;** Abdallah H. Alakayleh¹, Saddam Daradkeh¹, Sufyan Tahat¹, Sergio Bolanos¹, Waad Tarman¹, Yanal Masarweh¹, Shaheen Pouya¹, Jeffrey Suhling¹, John Evans¹, Sa'd Hamasha²; ¹*Auburn University*, ²*Binghamton University*
- 11:30 AM** (#75) **A Damage Model for the Strain Softening Behavior of Bi Containing Low Temperature Solder Alloys;** Pei-En Chou¹, Sean Lai¹, John Blendell¹, Carol Handwerker¹, Ganesh Subbarayan¹; ¹*Purdue University*
- 11:45 AM** (#84) **Impact of Multiple Reflows on Solder Joint Reliability and Drop Performance in BGA Assemblies;** Sufyan Tahat¹, Abdallah H. Alakayleh¹, Saddam Daradkeh¹, Yanal Masarweh¹, Waad Tarman¹, Sa'd Hamasha²; ¹*Auburn University*, ²*Binghamton University*
- 12:00 PM** (#94) **Influence of Bi and Sb Additions on the Shear Properties of SAC405 Individual Solder Joints;** Waad Tarman¹, Qais Qasaimah¹, Sergio Bolanos¹, Saddam Daradkeh¹, Abdallah H. Alakayleh¹, Sufyan Tahat¹, Yanal Masarweh¹, Omar Alhussien¹, John Evans¹, Sa'd Hamasha²; ¹*Auburn University*, ²*Binghamton University*
- 12:15 PM** (#241) **Thermal Fatigue Life Predictions for SAC Solder Joints Using a Modified Anand Model Incorporating Damage;** Golam Rakib Mazumder¹, Souvik Chakraborty¹, Mahbub Alam Maruf¹, Omma Sumaiya¹, Jeffrey Suhling¹, Pradeep Lall¹; ¹*Auburn University*



UNIVERSITY OF
TORONTO

atoms laboratory

Experimental-numerical
research program on lithium-ion
batteries and electric vehicles

**Hierarchical thermal and
electrochemical modeling,**
design optimization, and
experimental research across
multiple physical domains and
length scales from battery
electrode to vehicle levels

Vehicle-level

System
integration
[m]



Sub-cells

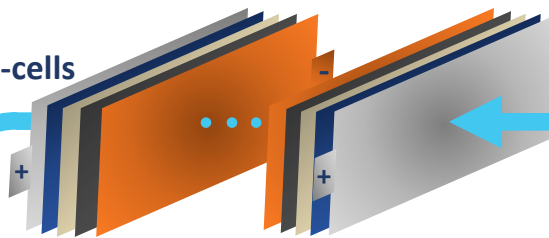

Electrode-level

Nano-to-micro
atomistic models
[nm - μ m]

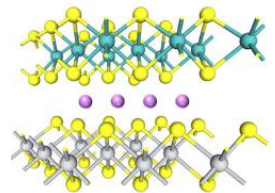

Cell-level

Coupled electrochemical
and thermal models
[mm]



Module-level

Conjugate heat transfer (CHT) models [cm]

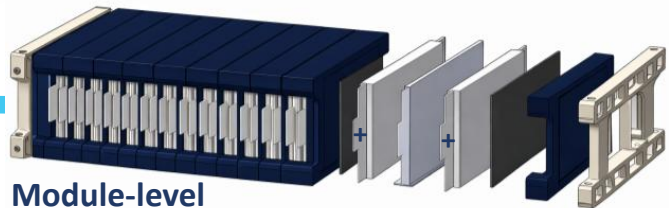

Pack-level

Reduced-order
models
[m]

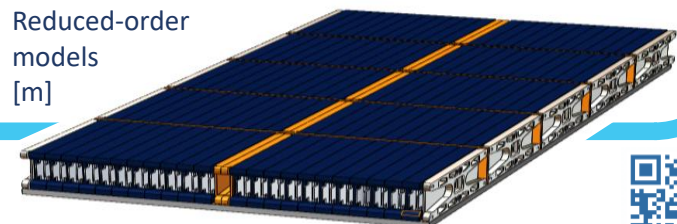

UNIVERSITY OF TORONTO
FACULTY OF APPLIED SCIENCE & ENGINEERING

Our Team

Join a team of talented graduate students and researchers advancing battery, electric vehicle, and electrification technologies at the University of Toronto, Canada's top innovation hub



Multiscale hierarchical thermal modeling

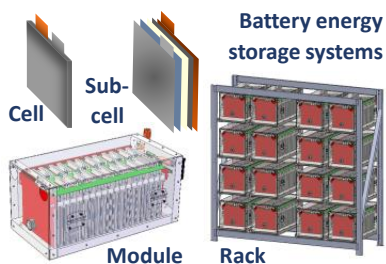

Thermal runaway mitigation

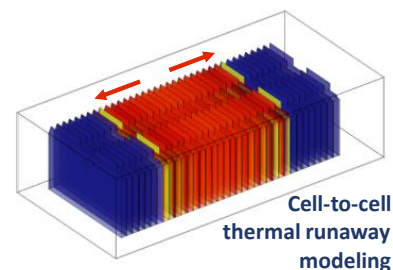

Battery thermal and electrochemical characterization

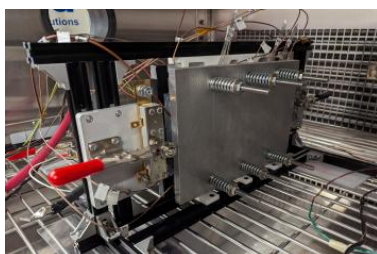

Battery degradation and lifetime

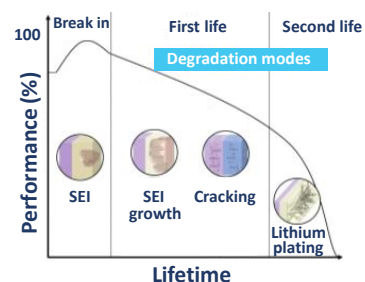

Deep learning surrogate modeling and design optimization

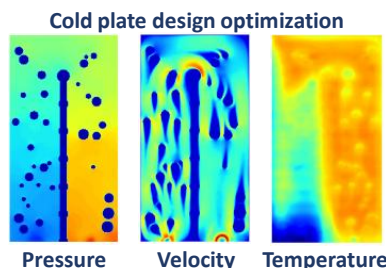

Nanoscale thermal and electrochemical transport

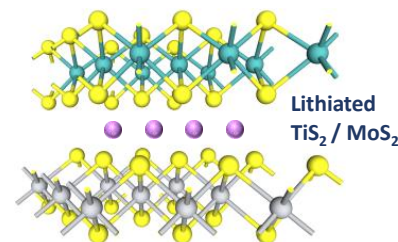

Our Partners



Electrification Hub (EHub)

electrification.utoronto.ca



Day 1: Wednesday, May 27th 2:00 PM–3:30 PM

TT-03 Advances in Data Center Cooling and Intelligent Thermal Control

AMARANTE 2-3 Chairs: *Jasvipul Chawla (KühlTherm Private Limited)*

Wangda Zuo

From Modelica to Physical AI: Reimagining Data Center Cooling for the Age of Intelligence

Peter de Bock

From Grid to Chip to Ambient: How AI Factory Energy-Stack System Power and Hot -Water Cooling Engineering Can Deliver Leaps in Energy Efficiency

Alfonso Ortega

Emerging Directions and Research Needs for Flow Network Thermal-Fluid Modeling of Liquid Cooling Systems for AI Factories

CT-03 Additive Manufacturing and Topology Optimization

DEL LAGO 1-2 Chairs: *Yueming Li (Meta) and Todd Otanicar (Boise State University)*

- 2:00 PM** **Enhancing Filmwise Flow Condensation Using 3d-Printed Wicked Condensers**; Mohammad Reza Shaeri¹, Sajjad Bigham², Vivek Mano Mohan², Jebin Joshua Isaac Raj², Maksym Demydovych¹; ¹*Advanced Cooling Technologies, Inc.*, ²*North Carolina State University*
(#4)
- 2:15 PM** **Evaluation of Flow and Heat Transfer in Morphologically Blended Porous Unit Cells for Advanced Heat Exchangers With Functionally Graded Designs**; Jaewon Park¹, Justin A. Weibel¹, Davide Ziviani¹; ¹*Purdue University*
(#72)
- 2:30 PM** **Interface-Filtering Structural Optimization of Forced-Convection Microchannel Heatsinks**; Tianye Wang¹, Xinyi Yu¹, Xiaoping Qian¹; ¹*University of Wisconsin - Madison*
(#119)
- 2:45 PM** **Experimental Calibration of Flow and Heat Transfer Performance Parameters in Metal Additively Manufactured Uniform Pin Fin Arrays**; Michael A. Barth¹, Boyu Duan¹, Liang Pan¹, Justin A. Weibel¹; ¹*Purdue University*
(#261)
- 3:00 PM** **Enhancing Heat Transfer Through a Microchannel Array in Heat Sinks**; Patrick P. Park¹, Xiangyu Li²; ¹*University of Tennessee*, ²*University of Tennessee, Knoxville*
(#267)
- 3:15 PM** **Thermal-Electrical IC Floorplanning and Package Heat Spreading Co-Optimization Algorithm**; Ashwin R. Kidambi¹, Justin A. Weibel¹, Liang Pan¹; ¹*Purdue University*
(#346)

ST-03 Automotive, Batteries, and Thermal Storage

DEL LAGO 3-4 Chairs: *Yunchun Yang (University of California, Los Angeles) and Onur Yenigun (imec)*

- 2:00 PM** **Boron Nitride Nanotube Reinforced Slot Liner for Improved Electric Motor Thermal Performance**; Nicholas J. Raffaele¹, Ohood Alsmairat¹, Amitav Tikadar¹; ¹*University of Mississippi*
(#131)
- 2:15 PM** **Heat Generation and Thermal Behavior in Large-Format Lithium-Ion Pouch Cells With Different Tab Configurations**; Christopher Doerrer¹, Yu Sung Chuo¹, Carlos Da Silva¹, Cristina H. Amon¹; ¹*University of Toronto*
(#164)
- 2:30 PM** **Thermo-Structural Trade-Offs and Optimal Cell Spacing in High-Power Battery Modules Using Aluminum Nitride Block Mounting**; Anish Pal¹, Sayan Karmakar¹, Constantine Megaridis¹; ¹*University of Illinois, Chicago*
(#326)
- 2:45 PM** **A Study on the Effect of Component Grain Size and Rehydration and Dehydration Times on Latent Heats of Glauber's Salt-Based PCM**; Matthew McGhee¹, Veeresh Ayyagari², Amir Shooshtari¹, Michael Ohadi¹; ¹*University of Maryland at College Park*, ²*Tesla*
(#150)
- 3:00 PM** **Dispatchable Thermal Energy Storage for HVAC Peak Demand Flexibility**; Paixun Lin¹, Achutha Tamraparni², Max Howell³, Khush Kapadia¹, Kyle Gluesenkamp², Som Shrestha², Shantonio Birch¹, Xiangyu Li³; ¹*ThermoVerse*, ²*Oak Ridge National Laboratory*, ³*University of Tennessee, Knoxville*
(#363)
- 3:15 PM** **Electro-Thermal-Electric Field Model-Based Immersion Cooling Channel Design for Large Pouch Lithium-Ion Batteries**; Sangwoo Kim¹, Sangyeop Lee², Jun Hyung Kim², Kyoungdoug Min²; ¹*Hyundai Mobis*, ²*Seoul National University*
(#455)

EF-03 Boiling Surface Enhancements

SEGURA 5 Chairs: Pratik Bhansali (AMD) and Kazuyoshi Fushinobu (Institute of Science Tokyo)

- 2:00 PM (#98) High-Speed Visualization of Flow Boiling Inversion and Hysteresis Using Self-Organized Laser Functionalization (SOLF) of Stainless Steel Surfaces in Water;** Logan Pettit¹, Graham Kaufman¹, Josh Gerdes¹, Andrew Reicks¹, Craig Zuhlke¹, George Gogos¹; ¹*University of Nebraska-Lincoln*
- 2:15 PM (#99) R134a Flow Boiling Enhancement With Self-Organized Laser Functionalization (SOLF) in Silicon Microchannels;** Josh Gerdes¹, Rahul Rajan¹, Craig Zuhlke¹, George Gogos¹; ¹*University of Nebraska-Lincoln*
- 2:30 PM (#143) Pool Boiling Enhancement via Hierarchical in-Plane Dendritic Nanostructures and Microscale Surface Patterning;** Michael Guerrero¹, Merve Baykal¹, Farzad R. Talabazar¹, Mustafa Ozsipahi², Adam Wilson², Michael Fish², Ashish Ghandi¹, Ali Beskok¹, Jung-Chih Chiao¹; ¹*Southern Methodist University*, ²*U.S. DEVCOM Army Research Laboratory*
- 2:45 PM (#245) Enhanced Pool Boiling Performance Using Self-Organized Laser Functionalization (SOLF) of Copper in a Dielectric Fluid;** Mohamed Marey¹, Truman Stoller¹, Josh Gerdes¹, Cooper Swoboda¹, Vlad Prapakchuk¹, George Gogos¹, Craig Zuhlke¹, Graham Kaufman¹; ¹*University of Nebraska-Lincoln*
- 3:00 PM (#362) Direct Laser Texturing of Silicon for Enhanced Direct-to-Chip Heat Transfer in Lidless Packages;** Arani Mukhopadhyay¹, Sayan Karmakar¹, Sreya Sarkar¹, Constantine Megaridis¹; ¹*University of Illinois, Chicago*
- 3:15 PM (#425) Materials Selection and Processing for Tunable Superlyophilic-to-Superlyophobic Surfaces;** Chance Brewer¹, Ilan Pechman¹, Nicholas Morgan², Shawn Putnam¹; ¹*University of Central Florida*, ²*University of Central Florida*

MR-03 Advanced Packaging and Hybrid Bonding

SEGURA 6 Chairs: Aniket Bharamgonda (University of Maryland at College Park) and Morgan Roddy (University of Arkansas)

- 2:00 PM (#86) Silane Treatment of Wafer Surfaces and NCF Adhesion for Enhanced Semiconductor Packaging Reliability;** Jiyeon Shin¹, Sojeong Lee¹, Minki Kim¹, Hyun-Soon Park², Min-Su kim¹; ¹*Korea Institute of Industrial Technology*, ²*Inha University*
- 2:15 PM (#176) A Simulation-Based Reliability Study of Hybrid Cu-Cu Bonds in 3D Packages With Cu-Epoxy Paste;** Unique Rahangdale¹, Sai Abhideep Pundla¹, Prasanna Jayaramu¹, Rohit K. Suthar¹, Meysam Emami¹, Md Raisul Islam¹, Yogesh M. Fulpagare¹, Dereje Agonafer¹; ¹*The University of Texas at Arlington*
- 2:30 PM (#188) Parametric Assessment of Thermomechanical Reliability of Sn-SnAg Microbumps in Heterogeneously Integrated Packages on Organic Substrates;** Pranav Srinivasan¹, Aniket Bharamgonda¹, Rohit M. Gandhi², Georgios Dogiamis³, Abhijit Dasgupta¹, Chris Bailey²; ¹*University of Maryland at College Park*, ²*Arizona State University*, ³*Deca Technologies Inc*
- 2:45 PM (#189) Reliability Assessment of Glass Substrates Used in Advanced Packages Under Power Traces;** Aniket Bharamgonda¹, Mumtahina I. Sukanya¹, Pranav Srinivasan¹, Abhijit Dasgupta¹, Ankur Srivastava¹; ¹*University of Maryland at College Park*
- 3:00 PM (#3) Thermal Cycling Reliability and Microstructure Study of a Carbon-Fiber Based Thermal Interface Material;** Pranay P. Nagrani¹, Kalind Baraya¹, Matthew Warbrick¹, Philipp Buchling¹, Sushumna Iruvanti¹; ¹*IBM*
- 3:15 PM (#234) Correlating Accelerated Testing Data on the Degradation of TIMs to Operational Lifetimes;** Ritwik Kulkarni¹, Nolan P. Gronowski¹, Amy Marconnet¹; ¹*Purdue University*

Day 1: Wednesday, May 27th 4:00 PM–5:30 PM

P-04 Thermal and Mechanical Challenges and Opportunities in Advanced Mobile, AI, Automotive, Space, and High-Power-Density Computing Devices

AMARANTE 2-3 Chairs: Victor Chiriac (*Global Technology Cooling Group*) Panelists: Rozalia Beica (*Rapidus*), Samuel Graham (*University of Maryland at College Park*), Yogendra Joshi (*DARPA*), Russell Kempt (*Diamond Foundry*), Amy Marconnet (*Purdue University*), Michael Ohadi (*University of Maryland at College Park*) and Ross Wilcoxon (*Collins Aerospace*)

CT-04 Vapor Chambers and Thermosyphons

DEL LAGO 1-2 Chairs: Deepak Sharma (*Oregon State University*) and Vincent Wheeler (*TauMat*)

- 4:00 PM Enhancing Vapor Chamber Performance With Microchannels;** Albert Chan¹, Yujin Park¹, Don Nguyen¹, Michael Brooks¹; ¹*Cisco Systems*
- 4:15 PM Experimental Characterization of a Two-Phase Loop Thermosyphon With Two Parallel Evaporators;** Syed Faisal¹, Manohar Bongarala¹, Rishav Roy¹, David J. Apigo¹, Sarwesh N. Parbat¹, Yang Liu¹, Mark Earnshaw¹, Todd Salamon¹; ¹*Nokia Bell Labs*
- 4:30 PM Prototyping and Performance Evaluation of Oscillating Heat Pipes for Data Center Cooling;** Shane Haydt¹, Dustin Caldwell¹, Andrzej Kuczek¹, Matthew Kennedy¹, Kimberly Saviers¹; ¹*RTX Technology Research Center*
- 4:45 PM Altering Filmwise Flow Condensation Behavior of Wetting Fluids via 3d-Printed Wick Structures;** Durga P. Ghosh¹, Jebin Joshua Isaac Raj¹, Vivek Mano Mohan¹, Mohammad Reza Shaeri², Sajjad Bigham¹; ¹*North Carolina State University*, ²*Advanced Cooling Technologies, Inc.*
- 5:00 PM Two-Phase Cooling Using Capillary-Driven and Hybrid Pumped Evaporation in Copper Wicks for High Heat Flux Applications;** Ali Ejaz¹, Bryan Eigenbrodt¹, Alfonso Ortega¹; ¹*Villanova University*
- 5:15 PM Design and Experimental Development of a Laser-Ablated Wick Aluminum Vapor Chamber for SiC MOSFET Thermal Management in EV Fast-Charger Converters;** Muhammad Awais¹, Saghir Amin¹, Jorge Luís M. Ortega¹, Óscar Samuel N. Carvalho¹, Francisco Brito¹, Nuno Costa², João Afonso¹, Vítor Monteiro¹; ¹*University of minho*, ²*Efacec Electric Mobility*

DC-04 Liquid Cooling Methods in Data Center Applications

DEL LAGO 3-4 Chairs: Mehmet Arik (*Auburn University*) and Sai Abhideep Pundla (*The University of Texas at Arlington*)

- 4:00 PM Commissioning and Performance Characterization of Liquid-to-Liquid CDUs for AI Factory Thermal Management;** Ali Heydari¹, Abdallah Soud², Mohammad Tradat¹, Bahgat Sammakia²; ¹*Nvidia Corporation*, ²*Binghamton University*
- 4:00 PM Advancements in Large-Scale Liquid Cooling Solutions: Deschutes CDU;** Hussameddine Kabbani¹, Jorge Padilla¹, Madhusudan Iyengar¹; ¹*Google*
- 4:00 PM HSIO Topology Design and Margin Measurement Analysis in Data Center Immersion Cooling Application;** Pengfei O. Cheng¹, Ying Zhang¹, Yulong Wang¹, Chenglong Gui¹, Kai Wang², Wenxi Yang², Jialiang P. Xu², Wenbin Tian², Weizhe Li², Tingting Kong², Xiaoguo J. Liang², Xu Zhang², Nishi Ahuja², Sung Ki Kim²; ¹*ByteDance Technology*, ²*Intel*
- 4:00 PM Performance Evaluation of Various Low-GWP Refrigerants for Pumped Two-Phase Direct-to-Chip Cooling;** Cheng-Min Yang¹, Gustavo Pottker¹, Abigail R. Van Wassen¹; ¹*Chemours Company*
- 4:00 PM Data Center Modeling of Direct-to-Chip Versus Direct-in-Chip Cooling;** Vivek Mano Mohan¹, Mohammad Reza Shaeri², Sajjad Bigham¹; ¹*North Carolina State University*, ²*Advanced Cooling Technologies, Inc.*
- 4:00 PM System-Level Analysis of IT-Facility Heat Exchanger Performance for Two-Phase Direct-to-Chip Coolid AI Data Centers;** Trevor Whitaker¹, Qingyang Wang¹, Serdar Ozguc¹, Akshith Narayanan¹, Lucas Beran¹, Richard Bonner¹; ¹*Accelsius*

EF-04 Topology Optimization, Design Automation

SEGURA 5 Chairs: Daniel Shoemaker (Pennsylvania State University) and Christopher Wise (U.S. DEVCOM Army Research Laboratory)

- 4:00 PM (#26) Limitations of Commercial Generative Design/Topology Optimization Software for Conjugate Heat Transfer Analysis of High Heat Flux Cold Plate Applications;** Siddharth Dasgupta; *DENSO International America*
- 4:15 PM (#305) Multi-Objective Optimization of Conjugate Heat Transfer in Offset Strip Fins With Inter-Column Gaps for Enhanced Convective Heat Transfer;** Jackson M. Jaworski¹, Marcus W. Ni², Donald George², Nicholas Tsolas¹; ¹*Auburn University*, ²*L3 Harris*
- 4:45 PM (Sponsored) Simdroid-EC Full-Scale Thermal Solutions From Chip to Data Center;** Weixing Yuan, Beijing Simulation World Engine Co., Ltd.
- 5:00 PM (#306) Multi-Objective Shape Optimization of Conjugate Heat Transfer in Offset Strip Fins With Additive Manufacturability Considerations;** Jackson M. Jaworski¹, Marcus W. Ni², Donald George², Nicholas Tsolas¹; ¹*Auburn University*, ²*L3 Harris*
- 5:15 PM (#424) Natural Convection Heat Sink Design via Conjugate Simulations and Simplified Topology Optimization;** Yanbo Huang¹, Michel Romero-Flores², Hunter Watts³, Justin A. Weibel¹; ¹*Purdue University*, ²*Schneider Electric*, ³*Sc*
- 5:30 PM (#158) Mathematical Interpretation of the Equivalent Thermal Conductivity for Bump-Structures in HBM;** Younghoon Hyun¹, Seongwoo Yang¹, Hyeonseok Ju¹, Youngdong Kim¹, Daewoong Lee¹, Heejin Lee¹, Kang-Wook Lee¹; ¹*SK hynix Inc.*

MR-04 Reliability of Liquid Cooling Technologies

SEGURA 6 Chairs: Manaswini Bhamidimarri (Purdue University) and David Huitink (University of Arkansas)

- 4:00 PM (#89) Comparative Thermal Resistance Evolution of Immersion-Compatible Thermal Interface Materials Under Power Cycling in Single-Phase Immersion Cooling;** Rohit K. Suthar¹, Meysam Emami¹, Seyedkamal Amininasab¹, Unique Rahangdale¹, Anto Barigala¹, Akiilesh Sivakumar¹, Sonkolon Barua¹, Gautam Gupta², Akshay B. Lakshminarayana³, Yogesh M. Fulpagare¹, Dereje Agonafer¹; ¹*The University of Texas at Arlington*, ²*Fabric⁸ Labs*, ³*Tesla*
- 4:15 PM (#190) Plastic BGA Substrate Reliability Study Under Air and Oil Immersion Aging;** Dikshya Bhattarai¹, Unique Rahangdale¹, Sonkolon Barua¹, Megha Tangri¹, Rohit K. Suthar¹, Ivneet K. Banga¹, Yogesh M. Fulpagare¹, Dereje Agonafer¹; ¹*The University of Texas at Arlington*
- 4:30 PM (#156) Thermo-Mechanical Characterization of Molded and Unmolded Substrates Under Single-Phase Immersion Cooling;** Rohit K. Suthar¹, Sonkolon Barua¹, Dikshya Bhattarai¹, Unique Rahangdale¹, Megha Tangri¹, Ivneet K. Banga¹, Yogesh M. Fulpagare¹, Dereje Agonafer¹, Karthekeyan Sridhar², Blake Travis², Rajen Murugan², Lalith Karsani², Osvaldo Lopez²; ¹*The University of Texas at Arlington*, ²*Texas Instruments*
- 4:45 PM (#404) Degradation Mechanisms of Thermal Interface Materials for Immersion Cooling Applications;** Manaswini Bhamidimarri¹, Karthika Haridas¹, Bijay Chettri¹, Jacey R. Birkenmeyer¹, Luz Sotelo¹, Shubhra Bansal¹; ¹*Purdue University*
- 5:00 PM (#429) Long-Term Stagnation Effects of Propylene Glycol-Based Coolants in Liquid-Cooled Data Center Systems;** Lochan Sai Reddy Chinthaparth¹, Pardeep Shahi², Ivneet K. Banga¹, Himanshu Modi², Md Raisul Islam¹, Sean Sivapalan², Saket Karajgikar², Ali Heydari², Mohammad Tradat², Dereje Agonafer¹; ¹*The University of Texas at Arlington*, ²*Nvidia Corporation*
- 5:15 PM (#87) Hydraulic Performance Verification of ECAM and Parallel-Fin Based Custom Cold Plates via CFD and Baseline Coolant Metrology for Accelerated Erosion Benchmarking;** Rohit K. Suthar¹, Seyedkamal Amininasab¹, Akiilesh Sivakumar¹, Lochan Sai Reddy Chinthaparth¹, Anto Barigala¹, Sai Abhideep Pundla¹, Yashwanth Reddy Gaddam¹, Braxton J. Smith¹, Dereje Agonafer¹, Gautam Gupta², Ian Winfield², Mike Matthews²; ¹*The University of Texas at Arlington*, ²*Fabric⁸ Labs*

· THIN · TINY · ANY SHAPE ·

Cooling that fits anywhere.

Plasma actuators just **200 μm thin**, shaped to **any surface** — flat, curved, circular or custom. No fans. No pumps. No moving parts.

0

MOVING PARTS

<20 dB

SILENT

200 μm

THIN FILM

mW

POWER CLASS



Active flow control

Electrically tuneable airflow with zero mechanical wear, vibration or failure modes.



Microscale integration

Thin-film form factor fits inside chips, devices and ultra-compact systems.



Programmable

Dynamic waveforms adapt airflow to real-time thermal demand on the fly.



Truly silent

Below the human hearing threshold — ideal for premium and sensitive environments.



Heat & cool in one

Combine plasma heat with forced convection to hold a target temperature with one device.



Energy efficient

Milliwatt-class operation versus the watts consumed by conventional fans and pumps.

HOW IT WORKS — DBD PLASMA ACTUATOR

01

AC Signal

Precision waveform drives the plasma actuator



02

Plasma

Surface ionization



03

Ionic Wind

EHD body force



04

Airflow

Up to 6 m/s

Powering the Future with Plasma Innovation

DAY 2: THURSDAY, MAY 28						
7:00 AM	Breakfast					Palazzo E-H
8:00 AM	CT-05 Advanced Packaging/HI Thermal Management <i>Del Lago 1-2</i>	ST-05 Liquid Cooling Solutions and System Integration <i>Del Lago 3-4</i>	EF-05 Topology Optimization, Two-Phase <i>Segura 5</i>	MR-05 Material Characterization <i>Segura 6</i>	TT-05 Extreme Environment Electronics <i>Amarante 2-3</i>	
9:15 AM	Break					
9:30 AM	 Keynote K-2: Thermal Challenges in HBM Memory Package and AI Systems Vladimir Noveski Director Advanced Memory Architecture Modeling and Simulations, Micro Technology Inc.				Segura 1-4	
10:30 AM	Coffee Break					Del Lago Prefunction
11:00 AM	CT-06A Single-Phase Cold Plates - Modeling <i>Del Lago 1-2</i>	DC-06 Air Cooling Methods for Data Centers <i>Del Lago 3-4</i>	EF-06 Physics-Informed Machine Learning and Predictive Analytics <i>Segura 5</i>	CT-06B Hotspot Mitigation <i>Segura 6</i>	P-06 Advanced Manufacturing: Enabling the Future of Electronics Thermal Management <i>Amarante 2-3</i>	
12:30 PM	Luncheon: ITherm 25 th Anniversary Celebration and Retrospective  Sushil Bhavnani, Auburn Univ.  Christin Amon, Univ. of Toronto  Alfonso Ortega, Villanova Univ.  Dereje Agonafer, UT Arlington  Paul Wesling, IEEE					Palazzo E-H
2:00 PM	CT-07A Two-Phase Cold Plates - Experimental <i>Del Lago 1-2</i>	ST-07 Single-Phase Immersion Cooling <i>Del Lago 3-4</i>	EF-07 AI Applications for Thermal Optimization <i>Segura 5</i>	CT-07B Thermal Interface Materials <i>Segura 6</i>	TT-07 Future of High-Performance Heat Sinks <i>Amarante 2-3</i>	
3:30 PM	Coffee Break					Del Lago Prefunction
4:00 PM	CT-08 Two-Phase Cold Plates - Modeling <i>Del Lago 1-2</i>	DC-08 Reliability Sustainability, Economics, and Scaling for Data Centers <i>Del Lago 3-4</i>	EF-08 Thermal Diagnostics, Metrology & Experimental Methods <i>Segura 5</i>	MR-08 Thermo-Mechanical Modeling <i>Segura 6</i>	P-08 Advanced Mechanics and Reliability <i>Amarante 2-3</i>	
5:30 PM	Student Poster and Networking Session					Segura 1-4
7:00 PM	Executive Committee Meeting (by Invitation)					

Day 2: Thursday, May 28th 8:00 AM–9:15 AM

TT-05 Extreme Environment Electronics

AMARANTE 2-3 Chairs: *Georges Pavlidis (University of Connecticut) and Jeremy Turcaud (Element Six)*

Saidur Bakaul

Ferroelectric AI Processors for Extreme Environments

Joana Catarina Mendes

Beating the Heat: Diamond as an Enabler for High-Performance Advanced Packages

CT-05 Advanced Packaging/Hi Thermal Management

DEL LAGO 1-2 Chairs: *Risa Miyazawa (IBM) and Yiwen Song (Pennsylvania State University)*

- 8:00 AM (#18) Thermoelectric Cooling Architecture for NVMe SSDs Using Controller-Mounted TEG and Dual NAND-Side TECs;** Petar Tsvetanov Beloev; *Technical Univeristy of Sofia*
- 8:15 AM (#82) Experimental Study of Temperature and Performance in Thermal-Enhanced SoC Packaging Structure;** Youngsang Cho¹, Hyunhee Kim¹, Wonsik Shin¹, Junso Pak¹, Heeseok Lee¹, Seung Wook Yoon¹; ¹*Samsung Electronics*
- 8:30 AM (#175) Thermal Analysis of Advanced 3D Co-Packaged Optics;** Yuanchen Hu¹, Mitul Modi¹, Krishna Bharath¹; ¹*Lightmatter*
- 8:45 AM (#253) Impact of Warpage and TIM Mechanical Compliance on the Thermal Performance of Large Multi-Chiplet Packages;** Onur Yenigun¹, Mario Gonzalez¹, Riet Labie¹, Kurt Herremans¹, Herman Oprins¹; ¹*imec*
- 9:00 AM (#292) On the Thermal Improvements From Lidless Packaging of IBM Z17;** Philipp Buchling¹, Kalind Baraya¹, Milnes P. David¹, A. Cory VanDeventer¹, Russell Kastberg¹, Sushumna Iruvanti¹, Alexis Jacques-Fortin¹, Jelani Owens¹, Hannah Wendling¹, Tobi Olowofela¹, Stephanie Allard¹, Jeffrey Coffin¹, Steve Ostrander¹, Mark D. Schultz¹; ¹*IBM*

ST-05 Liquid Cooling Solutions and System Integration

DEL LAGO 3-4 Chairs: *Anup Jain (AMD) and Mark Schultz (IBM)*

- 8:00 AM (#5) Design and Experimental Validation of Partitioned Flow Strategies for Optimized Microchannel Cooling;** Ron Zhang¹, Gill Fountain¹, KM Bang¹, Laura Mirkarimi¹, Suhail Sadiq¹, Arianna Avellan¹; ¹*Adeia*
- 8:15 AM (#271) Evolution of the IBM Z Cooling System;** Dustin W. Demetriou¹, Brandon Diaz¹, Milnes P. David¹, A. Cory VanDeventer¹, Randy Zoodsma¹, Francis Krug¹, Sushumna Iruvanti¹, Philipp Buchling¹, Steve Ostrander¹, John Torok¹, William Kostenko¹, Mark D. Schultz¹; ¹*IBM*
- 9:00 AM (#58) Advanced System Level Thermal Solutions With Liquid Cooling Loop : A Case Study on Thermal Performance in System Level Test Environment;** Srinath Reddy Yerakondappagari¹, Sridutt Tummalapalli¹; ¹*Intel*
- 9:15 AM (#42) Experimental Investigation of Heat Source Size Under Various Cooling Solutions Using a Silicon Thermal Test Vehicle (TTV);** Hyunhee Kim¹, Youngsang Cho¹, Heonwoo Kim¹, Junso Pak¹, Heeseok Lee¹, Seung Wook Yoon¹; ¹*Samsung Electronics*

EF-05 Topology Optimization, Two-Phase

SEGURA 5 Chairs: *Muneeshwaran Murugan (Oak Ridge National Laboratory) and Vincent Wheeler (TauMat)*

- 8:00 AM** (#69) **Coolant Water Requirements for Refrigerant Condensation Control in Pumped Two-Phase Coolant Distribution Units;** Braxton J. Smith¹, Sai Abhideep Pundla¹, Lochan Sai Reddy Chinthaparthi¹, Frediberto Hernandez¹, Dereje Agonafer¹; ¹*The University of Texas at Arlington*
- 8:15 AM** (#160) **Influence of Print Orientation on Geometric Variability and Design Implications for Additively Manufactured Cold Plates;** Zane L. Olige¹, Donald George², Nicholas Tsolas¹; ¹*Auburn University*, ²*L3 Harris*
- 8:30 AM** (#340) **Transient Multiscale Workflow for Thermal Analysis of 3DHI Chip Stack;** Mohammad Elahi¹, Max Bloomfield¹, Theodorian Borca-Tasciuc¹, Jacob Merson¹; ¹*Rensselaer Polytechnic Institute*
- 8:45 AM** (#345) **Optimization of Multi-Mode Thermal Metamaterials for Directional Heat Transfer in Faceted Thermophotovoltaic Systems;** Ziqi Yu¹, Taehwa Lee¹, Ercan (Eric) M. Dede¹; ¹*Toyota Research Institute of North America*
- 9:00 AM** (#451) **Density-Based Topology Optimization of a Multi-Outlet Fluid Manifold for Reduced Pressure Loss;** Abdallah Soud¹, Ahmad Gharaibeh¹, Bahgat Sammakia¹; ¹*Binghamton University*

MR-05 Material Characterization

SEGURA 6 Chairs: *Pranay Nagrani (IBM) and Megha Tangri (The University of Texas at Arlington)*

- 8:00 AM** (#252) **Investigation of the Tensile and Creep Responses of Mixed SAC-LTS Alloys With Varying Bi Concentration;** Souvik Chakraborty¹, Mahbub Alam Maruf¹, Golam Rakib Mazumder¹, Jeffrey Suhling¹, Pradeep Lall¹; ¹*Auburn University*
- 8:15 AM** (#422) **Associative ECAD–MCAD–CAE Workflow for PCB Vibration Analysis and Steinberg Fatigue Screening;** Yannick Sigmen¹, Mukund Rajamony¹; ¹*Maya HTT*
- 8:30 AM** (#266) **Material Characterization and Viscoelastic Shift of PCB Due to Thickness and Thermal Aging;** Megha Tangri¹, Unique Rahangdale¹, Sonkolon Barua¹, Akshay B. Lakshminarayana², Rohit K. Suthar¹, Meysam Emami¹, Dikshya Bhattarai¹, Dereje Agonafer¹; ¹*The University of Texas at Arlington*, ²*Tesla*
- 8:45 AM** (#379) **Enhancing the Mechanical Shock Resistance of Encapsulation Materials Using Carbon Nanotubes: A DOE-Based Experimental Study;** Yunus Yildiz, Kadri Onuk; *Roketsan Inc.*
- 9:00 AM** (#180) **Design of a Metrology Tool to Evaluate Degradation of Thermal Greases With Dynamic Warpage;** Sabina Bimali¹, Ritwik Kulkarni¹, Amy Marconnet¹; ¹*Purdue University*

Day 2: Thursday, May 28th 11:00 AM–12:30 PM

P-06 Advanced Manufacturing: Enabling the Future of Electronics Thermal Management

AMARANTE 2-3 Chairs: Arun Muley (Boeing) and Alfonso Ortega (Villanova University) Panelists: Brad Chen (Aegis Technologies), Zheng Liu (University of Michigan-Dearborn), Srdan Vasic (Extensis AG), Kumar Singh (Intel Foundries) and Remco van Erp (Corintis)

CT-06A Single-Phase Cold Plates - Modeling

DEL LAGO 1-2 Chairs: Sameer Rao (University of Utah) and Felipe Valenzuela-Gaete (IBM)

- 11:00 AM Thermal Performance of Immersion-Cooled Motor End Windings for Electrified Aircraft Propulsion;** Daniel V. Curl¹, Md Javed Hossain¹, Roy McCann¹, Han Hu¹; ¹University of Arkansas (#93)
- 11:15 AM CFD-Driven Multi-Objective Optimization of Microchannel Cold Plates for Non-Uniform Thermal Loads in Advanced Processor Packaging;** Yashwanth Reddy Gaddam¹, Mahesh K. Addanki¹, Sai Abhideep Pundla¹, Rohit K. Suthar¹, Dereje Agonafer¹, Gautam Gupta², Ian Winfield², Mike Matthews²; ¹The University of Texas at Arlington, ²Fabric⁸ Labs (#139)
- 11:30 AM Energy-Efficient Cooling Strategies With Integrated Bypass System for Multi-Chip Module Cooling;** Sehyeon Cho¹, Akshat Hetal Patel¹, Ketan Yogi¹, Gopinath Sahu¹, Tiwei Wei²; ¹Purdue University, ²University of California, Los Angeles (#154)
- 11:45 AM Coupled Opto-Thermal Modeling of a Multi-Chip LED Package With Immersion Cooling and Suspended Photoluminescent Particles;** Md Shafiqul Islam¹, Ahmet Mete Muslu², Mehmet Arik¹; ¹Auburn University, ²Georgia Institute of Technology (#173)
- 12:00 PM Numerical Evaluation of Heat Transfer Enhancement in Cold Plates Using v Shaped Ribs;** Dhruvalkumar K. Shah¹, Naimish Pandya², Sung Moon¹; ¹Cisco Systems, ²North Carolina State University (#247)
- 12:15 PM Design and Analysis of a Hybrid Liquid-Cooled Cold Plate With Phase Change Materials for Transient Thermal Management;** Sanjay Dharanipathy Sujatha¹, Vishruth P¹, Rohit Rajesh¹, Manikandan Sundararaj¹, Bharatiraja C¹, Siva Prasad Jangili Ganga², Deepak Mahalingam E¹; ¹SRM Institute of Science and Technology, ²Intel (#336)

DC-06 Air Cooling Methods for Data Centers

DEL LAGO 3-4 Chairs: Chinmay Bhatt (Dell Technologies) and Yogesh Fulpagare (The University of Texas at Arlington)

- 11:00 AM High-Efficiency Air Cooling in AI Data Center Chassis via Flow Control;** Sung Ki Kim¹, Casey Carte¹, Kevin Mistofsky¹, Dhruvalkumar K. Shah²; ¹Intel, ²Cisco Systems (#438)
- 11:15 AM Towards Physics Based CFD Digital Twins for Hyperscale Data Centers – Part I: Air Cooled Thermal and Airflow Performance Under Steady and Transient Conditions;** Yaser Hadad¹, Baris Dogruoz², Joe Dorsey, Bharath Ramakrishnan², Husam Alissa², Harsha Vaddireddy, Sashi Majety²; ¹Cadence Design systems, ²Microsoft (#274)
- 11:30 AM Smart Cooling for Smarter Servers: Matlab-Based Thermal Modeling of Data Centers;** Jacek Nazdrowicz¹, Maja Tuszynska²; ¹Lodz University of Technology, ²Technical University of Cracow (#205)
- 11:45 AM Thermal Performance Evaluation of TIM 1.5 Under Large TTV Warpage;** Navid Kazem (Sponsored)
- 12:00 PM Load-Aware Airflow Allocation in Hot Aisle Containment Configurations for Data Centers to Improve Energy Efficiency;** Jingru Benner¹, Dalya Al-bayati¹, Liang Niestemski¹, Wentao Wu²; ¹Western New England University, ²Massey University (#76)

EF-06 Physics-Informed Machine Learning and Predictive Analytics

SEGURA 5 Chairs: Pranay Nagrani (IBM) and Saeel Pai (Sandisk Corporation)

- 11:00 AM (#79) Investigating Thermal Runaway and Gas Venting in 18650 Lithium-Ion Cell: A Case Study Using ANSYS Fluent in-Built Battery Module;** Justin An¹, Aigbe E. Awenlimobor¹, Jiajun Xu; ¹University of the District of Columbia
- 11:15 AM (#85) AI-Driven Physics-Based Metamodel Enabling Rapid Thermal-Aware Floorplanning in 3d-Ic Exploration;** Chia Wei Tseng¹, Chou Tao¹, Chang Tzu An¹, Yueh Hsun Lin¹, Chee Wee Liu¹; ¹National Taiwan University
- 11:30 AM (#105) Dynamic Modelling of the Thermal Instability of Electro-Absorption Modulators;** David Coenen¹, Jorge E. Baker Ocon², Herman Oprins¹; ¹imec, ²TEC de Monterrey
- 11:45 AM (#186) FILM-Conditioned Physics-Informed Neural Networks for Fast Transient Thermal Prediction Across Varying Conductivities;** Mostafa Rahimi Dizadji¹, Vishal Talari¹, Braxton J. Smith¹, Meysam Emami¹, Seyedkamal Amininasab¹, Dereje Agonafer¹; ¹The University of Texas at Arlington
- 12:00 PM (#187) Physics-Informed U-Net for PIV Velocity Field Denoising;** Mostafa Rahimi Dizadji¹, Sandeep E. James¹, Sonkolon Barua¹, Prasanna Jayaramu¹, Joel J. Oommen¹, Mobina Hatami Miri¹, Braxton J. Smith¹, Dereje Agonafer¹, Jessica Gullbrand²; ¹The University of Texas at Arlington, ²Intel
- 12:15 PM (#398) A Complete Framework for Model Discovery of Flow Boiling Interface Dynamics Utilizing Physics Informed Machine Learning;** Logan M. Pirnstill¹, Forouzan Naderi¹, Chirag Kharangate¹; ¹Case Western Reserve University

CT-06B Hotspot Mitigation

SEGURA 6 Chairs: Vibin Shalom Simon (Nvidia Corporation) and Ketan Yogi (Purdue University)

- 11:00 AM (#95) Integration of a Solid-State Fan for Enhanced Heat Dissipation in Portable SSD;** ZHENGWEI CHEN¹, Li Chen², Saeel Pai², Ran Ran², Surya Deb²; ¹Purdue University, ²Sandisk Corporation
- 11:00 AM (#135) Thermal Management of Multiple Hotspots Using Variable Fin Configurations;** Tahsin Ul Haque¹, Akin Chakma¹, Amitav Tikadar¹; ¹University of Mississippi
- 11:00 AM (#275) Pin-Fin Enhanced Direct Liquid Jet Impingement Cooling of Uniform and Non-Uniform Heat Fluxes;** Georg Elsinger¹, Herman Oprins¹, Vladimir Cherman¹, Geert Van der Plas¹, Zsolt Tokei¹, Eric Beyne¹, Ingrid De Wolf¹; ¹imec
- 11:00 AM (Sponsored) Sponsored Talk;** Adrian Perez
- 11:00 AM (#344) Cold Plate Design Optimization Technique to Reduce Thermal Imbalance in Power Module With Nonuniform Heat Flux;** Himel Barua¹, Gui-Jia Su¹, Shajjad Chowdhury¹, Burak Ozpineci¹; ¹Oak Ridge National Laboratory
- 11:00 AM (#442) Flow-Boiling Response of a Two-Phase Cold Plate Under Uniform and Linear Hotspot Heat Flux;** Farzaneh Hosseini¹, Najmeh Fallahtafti², Yaser Hadad³, Vahideh E. Radmard⁴, Mohammad Tradat⁴, Bahgat Sammakia¹; ¹Binghamton University, ²Vertiv, ³Cadence Design systems, ⁴Nvidia Corporation



Yujui Lin

2026 ASME K-16 Graduate Student Paper of the Year Award
 2025 ASME EPPD Student Member of the Year Award
 2025 IEEE ITherm conference Prof. Avram Bar-Cohen Best Paper Award

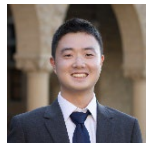

Luke Min

2025 MRS Fall Meeting, Best Student Presentation Award
 2025 ASME InterPACK2025 3rd Place in the Grayeli, Best Poster Award
 2025 IEEE ITherm conference Best Paper Runner-Up Award

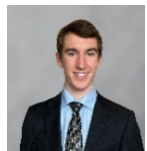

Matthew Coughlin

2025 ASME InterPACK2025 1st Place in the Grayeli, Best Poster Award
 2025 IEEE ITherm conference Best Paper Runner-Up Award



Mehdi Asheghi, Adjunct Professor

2026 NVIDIA Research Faculty Fellow

An annual honor recognizing exceptional academic collaborators whose work significantly enhances NVIDIA Research.



2026 NVIDIA Research Faculty Fellow

Ken Goodson
 Vice Provost for Graduate Education and Postdoctoral Affairs
 Davies Family Provostial Professor
 Professor of Mechanical Engineering, Stanford University

The Nanoheat Laboratory Members



Dr.
H. Kwon¹



Dr.
D. Kong²



Dr.
Y. Lin³

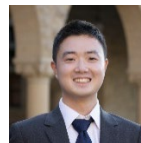

Luke
Min⁴



Matthew
Coughlin⁵



Hongchi
(Leo) Liu⁶



Noah
Wang⁷



Jillian
Anderson⁸

- 1) Postdoctoral Scholar (2022-26), Assistant Professor, Kyung Hee University, Korea
- 2) Postdoctoral Scholar (2024-25), Electronics and Telecommunications Research Institute (ETRI), South Korea
- 3) Research Scientist at NVIDIA Research (June 2026), Stanford (2020-2026), Nvidia Internships (2023 and 2024)
- 4) 3rd year PhD student, Internships: TSMC (June 2024), Nvidia (June 2026) (Stanford SGF/EDGE Fellow)
- 5) 1st year Ph.D. student, two-phase cooling and liquid metal thermal interface materials
- 6) MS Student, Stanford (204-26), Tesla (2026)
- 7) MS Student, Internships (NVIDIA 2025), TSMC (2026), single- and two-phase cooling
- 8) 6th Year Ph.D. student

The Nanoheat Members' Presentations at the ITherm and ECTC 2026

Wed, May 27

- **Component-Level Thermal Management**
- **Heat Spreaders 8:00 AM - 9:15 AM (Room 2)**

□ Luke Min et al., Thermal Conductivity Mapping of Diamond-Copper Composite using Scanning TDTR Microscopy (8:00 AM - 8:15 AM)

□ Matthew Coughlin et al., Enhancing Capillary-Driven Evaporator Performance by Engineering Pin Fin Wick Permeability in Three Dimensions (9:00 AM - 9:15 AM)

- **Microgaps and Embedded Cooling 8:00 AM - 9:15 AM (Room 1)**

□ Dr. Heungdong Kwon et al., Microfabrication of Large-area (3 cm × 3 cm) Si-based Microchannel with 3D Manifold Cooler for Hetero-geneous Integrated Microsystems 8:45 AM - 9:00 AM, Room 1

- **Emerging Technologies and Fundamentals**

Two-Phase Heat Transfer: Flow Boiling and Microstructures
11:00 AM - 12:30 PM (Room 4)

□ Dr. Yujui Lin et al., Exploring the Physics of Capillary Boiling and Bubble Dynamics in Hierarchical Silicon Wicks using Coupled Thermal Imaging and High-Speed Flow Visualization, 11:15 AM - 11:30 AM.

Thu, May 28

- **Tech Talk: Future of High-Performance Heat Sinks**

2:00 PM - 3:30 PM

□ Dr. Mehdi Asheghi et al., High-Performance Capillary-based Two-Phase Cooling Solution for Energy Efficient Data Centers

Fri, May 29

- **System-Level Thermal Management**

Two-Phase Cooling & Flow Control 11 AM - 12:30 PM (Rm. 2)

□ Hongchi (leo) Liu et al., Shallow Pool Boiling of Novec 649 on Planar/Finned Copper Inverse Opal (CuIOs) Structures 12:15 PM - 12:30 PM.



Fri, May 29

- **Session 30: Thermal Management and Cooling Simulation 9:30 a.m. - 12:35 p.m.**

□ Dr. Yujui Lin et al., High-Fidelity Package-Level Conjugate Thermal-Flow Simulation for a Memory-on-Logic 3D System with Embedded Liquid-Cooling 11:55 AM - 12:15 PM

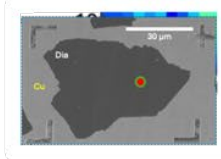
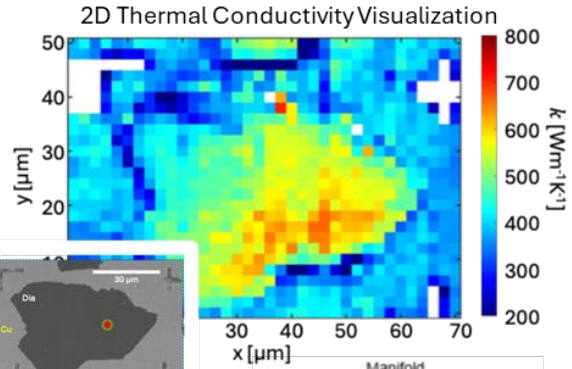

Si μ -Cooler
(3² cm²)

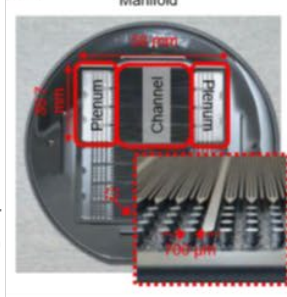

Temp. & bubble heatmaps

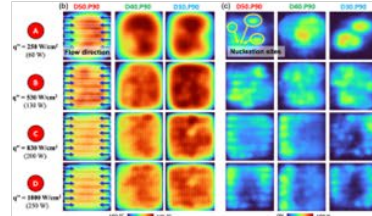

Novec 649 bubble dynamics

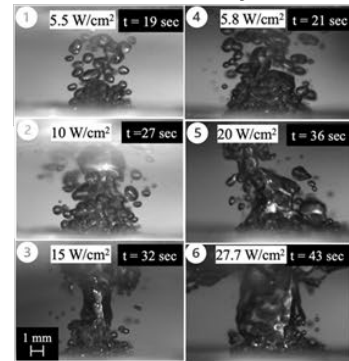

Temp. Profiles
for
HBM-on-GPU
Architecture

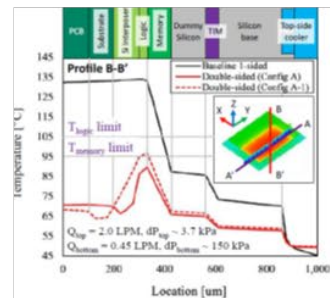

Day 2: Thursday, May 28th 2:00 PM–3:30 PM

TT-07 Future of High-Performance Heat Sinks

AMARANTE 2-3 Chairs: *Angie Han (Luxshare) and Constantine Megaridis (University of Illinois, Chicago)*

Xiaoping Qian

Next-Generation Thermal Management Through Topology Optimization and Additive Manufacturing

Mehdi Asheghi

High-Performance Capillary-Based Two-Phase Cooling Solution for Energy Efficient Data Centers

William D. Gerstler

Thermal Management as a Product Enabler: High-Performance Heat Sinks for Energy, Electrification, and Data Center Systems

CT-07A Two-Phase Cold Plates - Experimental

DEL LAGO 1-2 Chairs: *Faisal Ahmed (Auburn University) and Anil (Neil) Yuksel (Ecolab)*

- 2:00 PM Performance Comparison of Two-Phase Immersion Cooling vs Single-Phase Liquid Cooling for High Power Density Bare Die Packages;** Tanya Liu¹, Jorge Padilla¹, Madhusudan Iyengar¹; ¹*Google*
- 2:15 PM Surface Treatment Effects in Expanding Channel Two-Phase Flow Boiling;** Mark D. Schultz¹, Graham Kaufman², Josh Gerdes², George Gogos², Craig Zuhlke², Timothy Chainer¹; ¹*IBM*, ²*University of Nebraska-Lincoln*
- 2:30 PM Effects of Re-Entrant Cavity Geometries on Sub-Cooled Flow Boiling;** Zachary Wong¹, Naarendharan Meenakshi Sundaram¹, Subramanian Iyer¹, Timothy Fisher¹; ¹*University of California, Los Angeles*
- 2:45 PM Effect of Superhydrophilic Hierarchical Structure on Two-Phase Cooling With Membrane-Based Liquid Film Boiling at Above 1kW/Cm²;** Wenzheng Jiang¹, Rong o. Fu¹, Chuan Chen¹, Yunting Liu¹, Yeye o. Li¹, Qidong Wang¹, Liqiang Cao¹; ¹*Institute of Microelectronics of The Chinese Academy of Sciences*
- 3:00 PM Experimental Characterization of Two-Phase Flow in Cold Plates for Battery Thermal Management;** Shuai Che¹, Cesar Rosas-Vazquez¹, Nicholas Bush¹, Tomasz Kulakowski¹, Solomon Adera¹; ¹*University of Michigan*
- 3:15 PM Development of Two-Phase Heat Transfer in Skived-Fin Microchannel Cold Plate via Integrating a Distributor Configuration for Electronic Cooling Applications;** Mohammed Sulaiman¹, Kuan-Fu Sung¹, Yu-Ze Chen¹, Cheng-Hung Hsu¹, Yu-Lin Chen¹, Kuei Feng Chiang¹, Fang-Chou Lin¹; ¹*Asia Vital Components Co., Ltd.*

ST-07 Single-Phase Immersion Cooling

DEL LAGO 3-4 Chairs: *Arad Azizi (Solstice Advanced Materials) and Andres Sarmiento (University of Maryland at College Park)*

- 2:00 PM A Heat Pipe Heat Exchanger-Integrated Single-Phase Immersion Cooling System for Data Centers;** Jungchan Moc¹, Sukkyung Kang¹, Seonmin Park¹, Jungcho Lee¹; ¹*Ajou University*
- 2:15 PM The Study of Single Phase Immersion Cooling on 2U Switch;** Yaoyin Fan¹, Zhen Wang¹, Peng Wei¹, Chengzhi Liu¹; ¹*Celestica*
- 2:30 PM Thermo-Electrical Evaluation of a Single-Phase Immersion Cooling System Using Tier-1 Enterprise Servers and a Novel Bio-Based Synthetic Ester;** Beau Van Vaerenbergh¹, Marion Kerbrat¹, Pieter Struelens¹; ¹*Oleon*
- 2:45 PM Impact of Impinging Flow in Single Phase Immersion Cooling for High Performance Data Center System;** Sung Ki Kim¹, Casey Carte¹, Nishi Ahuja¹; ¹*Intel*
- 3:00 PM Numerical Investigation of Coolant Parameter Effects on Component-Level Heat Capture Ratio in Hybrid Immersion and Direct-to-Chip Cooling;** Akiilessh Sivakumar¹, Lochan Sai Reddy Chinthaparthi¹, Anto Barigala¹, Khang Nguyen¹, Rohit K. Suthar¹, Vibin S. Simon¹, Dereje Agonafer¹; ¹*The University of Texas at Arlington*
- 3:15 PM Power Electronics Thermal Management via Immersion Cooling;** Biruk Teka Gidreta¹, Hrushikesh Jadhav¹, Al-Thaddeus Avestruz¹, Solomon Adera¹; ¹*University of Michigan*

EF-07 AI Applications for Thermal Optimization

SEGURA 5 Chairs: Zheng Liu (*University of Michigan-Dearborn*) and Dhruvalkumar Shah (*Cisco Systems*)

- 2:00 PM** (#45) **Deep Neural Networks Framework for Optimizing Laptop Airflow Rate;** Byeongchan Kim¹, Jihong Kim¹, Haein Chung¹; ¹*Samsung Electronics*
- 2:15 PM** (#48) **Interface-Constrained Multi-Domain PINNs for Thermal Spreading Analysis in Multichip Power Modules;** Yonghun Kim¹, Haeun Lee², Changhyeon Yoon³, Changwoo Han⁴, Dongmin Shin⁴, Jungwan Cho⁵, Sooyoung Lee⁶, Hyoungsoon Lee⁶; ¹*Seoul*, ²*Yeungnam Univ.*, ³*Chung-Ang University*, ⁴*Hyundai Motor Company*, ⁵*Sungkyunkwan University*, ⁶*Chung-Ang University*
- 2:30 PM** (#68) **Physics Guided Design of Oscillating Heat Pipes for Data Center Cooling;** Nirmal Rai¹, Miad Yazdani¹, Kimberly Saviers¹; ¹*RTX Technology Research Center*
- 2:45 PM** (#71) **Simplified Charge Estimation in Plate Condensers for Pumped Two-Phase Systems;** Braxton J. Smith¹, Sai Abhideep Pundla¹, Lochan Sai Reddy Chinthaparthi¹, Mahesh K. Addanki¹, Dereje Agonafer¹; ¹*The University of Texas at Arlington*
- 3:00 PM** (#152) **A Simplified Shift-Left Methodology for Early Thermal Analysis of Heterogeneously Integrated Chip-Package System;** Aakrati Jain¹, Sujyesh Aanandh Manjunathan², Lee Johnson¹, Christine Bui¹, Don Labreque¹, Akif Ali¹, Cheng Chi¹; ¹*IBM*, ²*Synopsys, Inc*
- 3:15 PM** (#328) **DeepONet-Enabled Fast and Scenario-Aware Spatial Temperature Prediction of a Vertical Power Delivery Module for Hyperscale Data Centers;** Mingeun Choi¹, Michael Herndon², Kawika Uechi², Nabil Akel², Satish Kumar¹; ¹*Georgia Institute of Technology*, ²*Claros, Inc.*

CT-07B Thermal Interface Materials

SEGURA 6 Chairs: Chetan harsha Edara (*Arizona State University*) and Pranay Nagrani (*IBM*)

- 2:00 PM** (#441) **Stability of Two-Phase in-Sn-Bi Metallic Thermal Interface Materials Under Ambient and Immersion Liquid Cooling Conditions;** Choong-Un Kim¹, Dong Seok Lee¹, Je-Young Chang², Valery Ouharov-Bancalero²; ¹*The University of Texas at Arlington*, ²*Intel*
- 2:15 PM** (#157) **Functional Thermal Imaging and Effect of Temperature on Liquid Thermal Interface Material (LTIM) for Solid State Drive;** Vigneshwaram Kumaresan¹, Mutharasu Devarajan¹; ¹*Sandisk Corporation*
- 2:30 PM** (Sponsored) **Sponsored Talk;** Remco van Erp
- 3:00 PM** (#263) **Development and Thermal Characterization of a High Thermal Conductivity Die Attach Film for Advanced Packaging Applications;** Jianyu Du¹, Lang Chen¹, Wei Wang¹, Chi Zhang¹; ¹*Peking University*
- 3:15 PM** (#10) **Thermal Conductivity Enhancement and Interfacial Thermal Resistance Control in Ga-Based TIM With Mo-Coated Diamond via Molecular Dynamics Simulation and Experimental Analysis;** Jangwon Kim¹, Se Hoon Hwang¹, Ho-Nyun Lee¹, Wooyoung Lee², Min-Su kim¹; ¹*Korea Institute of Industrial Technology*, ²*Yonsei University*
- 3:30 PM** (#454) **FlexiMetal: A Pump Out Resistant High Performance Metallic Gel-Like Thermal Interface Material for CPU, GPU and Other Electronic Cooling Applications;** Himanshu Pokharna¹, Sangram K. Samal², Yogesh M. Fulpagare³, Chi-Chuan Wang²; ¹*Deep Materials*, ²*National Yang Ming Chiao Tung University*, ³*The University of Texas at Arlington*

Day 2: Thursday, May 28th 4:00 PM–5:30 PM

P-08 Advanced Mechanics and Reliability

AMARANTE 2-3 Chairs: Francis McCluskey (University of Maryland at College Park) and Ross Wilcoxon (Collins Aerospace) Panelists: Bongtae Han, David Huitink (University of Arkansas), Pranay Nagrani (IBM), Paul Paret (National Laboratory of the Rockies), Josh Pennington () and Gamal Refai-Ahmed (AMD)

CT-08 Two-Phase Cold Plates - Modeling

DEL LAGO 1-2 Chairs: Kalind Baraya (IBM) and Faizaan Mohammed (Georgia Institute of Technology)

- 4:00 PM (#41) High-Fidelity Reduced-Physics Modeling of Two-Phase Flow Through Counter-Flow Expanding Channels Cold-Plate;** Pritish Parida¹, Mark D. Schultz², Timothy Chainer²; ¹IBM Research, ²IBM
- 4:15 PM (#146) Three-Dimensional Two-Phase CFD Modeling and Experimental Validation of Two-Phase Cold Plates;** Mohammad A. Elmi¹, Alfonso Ortega¹, Yousaf Shah¹, Ali Heydari², Yaman Manaserh², Sreenivas Viyyuri³; ¹Villanova University, ²Nvidia Corporation, ³Synopsys, Inc
- 4:30 PM (#293) Transient Thermal Analysis of Porous Filled Energy Storage Systems With Application in a Lithium-Ion Battery Module;** Charles R. Hoole¹, Shadi Mahjoob¹; ¹California State University, Northridge
- 4:45 PM (#399) 3D Computational Simulation of Vertical Downflow Condensation Heat Transfer;** Thanh Hoang Phan¹, Chirag Kharangate¹; ¹Case Western Reserve University
- 5:00 PM (#405) Enhancing Thermal Management Through YOLO-Based Analysis of Bubble Dynamics in Bottom-Wall Flow Boiling Under Normal Gravity;** Forouzan Naderi¹, Chirag Kharangate¹; ¹Case Western Reserve University
- 5:15 PM (#421) Design and Testing of a 2-Phase Cold Plate for the AI Industry;** Leroy Benjamin, Matthew Connors, Nelson Germet, Trevor Moody, Matt Romey, Victor Nosivitsky; *Boyd Corporation*

DC-08 Reliability Sustainability, Economics, and Scaling for Data Centers

DEL LAGO 3-4 Chairs: Sashi Majety (Microsoft)

- 4:00 PM (#389) Reducing PUE in U.S. Data Centers Through LNG Regasification Cold Energy Recovery: Integrated Co-Located and Remote Cooling Architectures;** Ijaz Fazil Syed Ahmed Kabir¹, Mohan Kumar Gajendran², Ng Yin Kwee Eddie¹, Hakeem Niyas³; ¹Nanyang Technological University, ²University of Missouri-Kansas City, ³Rajiv Gandhi Institute of Petroleum Technology
- 4:00 PM (#259) Advanced Cooling-Driven Design of PCS-HBD: Enabling High-Density, Sustainable AI for the Grid-Interactive Era;** Dou Shen¹, Zhenghui Wu¹, Jun Zhang², Nishi Ahuja³, Carrie Chen³, Lang Yuan⁴, Yongzhan He¹, Peilong Wang¹, Canghai Gu¹; ¹Baidu, ²Unaffiliated, ³Intel, ⁴Oracle
- 4:15 PM (Sponsored) Sponsored Talk;** Andres Abraham
- 4:15 PM (#33) Temperature-Aware GPU Workload Distribution Method to Enable Stable Waste Heat Utilization in Data Centers;** Naruto Arai¹, Naoki Hanaoka¹, Toshihiro Hayashi¹; ¹NTT
- 4:15 PM (#35) Reliability Study on Negative Pressure Cold Plate Liquid Cooling Solution for Data Center Application;** Wenbin Tian¹, Ting Tian², Chenglong Gui², Yulong Wang², Chen Shen², Tong Wu², Xing Lv², Tangbo Jing², Yuanlin Ren², Wenxi Yang¹, Tingting Kong¹, Jialiang P. Xu¹, Xiaoguo J. Liang¹, Kai Wang¹, Xu Zhang¹, Nishi Ahuja¹, Sung Ki Kim¹, Casey Carte¹; ¹Intel, ²ByteDance Technology
- 4:15 PM (#145) Reliability and Availability Analysis of a Hybrid-Cooled Modular Edge Micro Data Center;** Amir Hossein Zabihi Tari¹, Diganta Das¹, Andres Sarmiento¹, Michael Ohadi¹; ¹University of Maryland at College Park

EF-08 Thermal Diagnostics, Metrology & Experimental Methods

SEGURA 5 Chairs: *Shoib Ahmed (Meta Platforms) and Suhas Tamvada (Tesla)*

- 4:00 PM (#59) Experimental Method for Measuring MOSFET Junction Temperature During Heating With PCM Integration;** Giovanina Bell¹, Rachel McAfee², Christopher Wise², Michael Fish², Francis P. McCluskey¹; ¹*University of Maryland at College Park*, ²*U.S. DEVCOM Army Research Laboratory*
- 4:15 PM (#170) Nitrogen and Carbon Dioxide Gas Flows Under Sudden Contraction and Expansion at the Microscale;** Soroush Niazi¹, Yoav Peles¹; ¹*University of Central Florida*
- 4:30 PM (#184) Modeling Finite Laser Spot Effects in FDTR Measurements of Nanoline Gratings for Device Thermal Characterization;** Seungwon Park¹, Abhishek Pathak², Alan McGaughey¹, Jonathan A. Malen¹; ¹*Carnegie Mellon University*, ²*George Washington University*
- 4:45 PM (#285) Transient Thermoreflectance Imaging of a Gallium Oxide Transistor With Near Bandgap Probing by DUV Illumination;** Dominic Myren¹, Daniel M. Dryden², Cameron A. Gorsak³, Hari P. Nair³, Ahmad E. Islam², Andrew J. Green², Georges Pavlidis¹; ¹*University of Connecticut*, ²*Air Force Research Laboratory*, ³*Cornell University*
- 5:00 PM (#347) Experimental Thermal Analysis of Air Jet Impingement Through a Confined Channel Filled With Metal Foam;** Dalton Caldwell¹, Shadi Mahjoob¹; ¹*California State University, Northridge*
- 5:15 PM (#430) Simulation-Driven Test Vehicle Design for Thermal Conductivity Characterization of Thin Films;** Karthik Guda Vishnu¹, Liu Jiang, Kai Ma¹, El Mehdi Bazizi¹; ¹*Applied Materials*

MR-08 Thermo-Mechanical Modeling

SEGURA 6 Chairs: *Pallavi Jithendriyan (Arizona State University) and Sharan Kishore (NXP Semiconductors)*

- 4:00 PM (#204) Modeling Thermal Effects on Capacitive MEMS Accelerometer Performance in MATLAB/Simulink;** Jacek Nazdrowicz¹, Michal Szermer¹, Maja Tuszynska²; ¹*Lodz University of Technology*, ²*Technical University of Cracow*
- 4:15 PM (#251) CNN-Transformer Model for Structure Function Thermal Characterization in Multilayer Semiconductor Packages;** Wonbin Song¹, Guesuk Lee², Byeng D. Youn¹; ¹*Seoul National University*, ²*Korea Electronics Technology Institute*
- 4:30 PM (#310) A Neural Network Based Failure Probability Prediction From Sequential Resistance Measurements in Thermal Cycling Reliability Testing;** Shaheen Pouya¹, Mostafa Rahgouy¹, Abdallah H. Alakayleh¹, Sa'd Hamasha², Jeffrey Suhling¹; ¹*Auburn University*, ²*Binghamton University*
- 4:45 PM (#433) Physics-Informed Machine Learning Framework for Predictive Warpage Control in Fan-Out Molded Core Substrates;** Pallavi Jithendriyan¹, Chris Bailey¹, Abhijit Dasgupta²; ¹*Arizona State University*, ²*University of Maryland at College Park*
- 5:00 PM (#439) Thermomechanical Analysis for Advanced Packaged Redistribution Layers at Sub 5 Micron Line/Spacing;** Rohit M. Gandhi¹, Pranav Srinivasan², Aniket Bharamgonda², Nikhitha Poornabodha¹, Nicholas Rolston¹, Abhijit Dasgupta², Chris Bailey¹; ¹*Arizona State University*, ²*University of Maryland at College Park*
- 5:15 PM (#90) Advancements in Pre-Silicon Thermal Modeling Methodologies;** Lior Samogora¹, Tomer Turgeman¹, Maxim Lerman¹, Omer Raz¹; ¹*Intel*

DAY 3: FRIDAY, MAY 29					
7:00 AM	Breakfast <i>Palazzo E-H</i>				
8:00 AM	CT-09 Impingement Cooling <i>Del Lago 1-2</i>	ST-09 Transient Thermal Management, Controls, and Emerging Applications <i>Del Lago 3-4</i>	EF-09 Nanoscale and Transistor-Level Thermal Transport <i>Segura 5</i>	MR-09 Solder Joints - II <i>Segura 6</i>	TT-09 Liquid Cooling for Data Center <i>Amarante 2-3</i>
9:15 AM	Break				
9:30 AM	 Keynote K-3: The Future of 3D Heterogenous Integration <i>Segura 1-4</i> Madhavan Swaminathan Department Head of Electrical Engineering & William E. Leonhard Endowed Chair Director, Center for Heterogeneous Integration of Micro Electronic Systems, The Pennsylvania State University				
11:00 AM	CT-10 Single-Phase Cold Plates – Experimental <i>Del Lago 1-2</i>	DC-10 Hybrid and Novel Cooling Methods for Data Centers <i>Del Lago 3-4</i>	EF-10 Thermal Characterization of Advanced Materials <i>Segura 5</i>	ST-10 Two-Phase Cooling and Flow Control <i>Segura 6</i>	P-10 Cooling for AI and AI for Cooling <i>Amarante 2-3</i>
12:30 PM	Luncheon: ITherm Awards and Organizer Recognition <i>Palazzo E-H</i>				
2:00 PM	<i>Del Lago 1-2</i>	<i>Del Lago 3-4</i>	<i>Segura 5</i>	<i>Segura 6</i>	ITherm 2027 Planning Meeting <i>Amarante 2-3</i>

Day 3: Friday, May 29th 8:00 AM–9:15 AM

TT-09 Liquid Cooling for Data Centers

AMARANTE 2-3 Chairs: George Gogos (University of Nebraska-Lincoln) and Angie Han (Luxshare)

Milad Samie

How to Achieve 100% Heat Capture on 500kW+ Racks

Berhanu Wondimu

Opportunities and Challenges of Direct to Chip Liquid Cooling

CT-09 Impingement Cooling

DEL LAGO 1-2 Chairs: Biruk Teka Gidreta (University of Michigan) and Remco van Erp (Corintis)

- 8:00 AM (#44) Enhancing Two-Phase Direct Liquid Jet-Impingement Cooling With Etched and Laser-Ablated Pin-Fins for 2.5D Semiconductor Packages;** Insik Lee¹, Sangha Baek¹, Seungwoo Kim¹, Jaechoon Kim², Youngsuk Nam¹; ¹KAIST, ²Samsung Electronics
- 8:15 AM (#136) Design, Fabrication and Characterization of 3D Porous Heat Sinks for Jet Impingement Cooling;** Luis Enrique Alvarado-Mendoza¹, Colton Love¹, Albert Patterson¹, Jorge Alvarado¹; ¹Texas A&M University
- 8:30 AM (#178) Direct-on-Chip Jet Impingement Cooling With Phase Separation Membrane;** Yunchun Yang¹, Ketan Yogi², Tiwei Wei¹; ¹University of California, Los Angeles, ²Purdue University
- 8:45 AM (#303) Thermal Characterization of Thin-Film Ceramics Using Liquid-to-Liquid Heat Exchange Method;** Tijesunimi O. Akintunde¹, Matthew Norris¹, Jason Schmitt², Memo Romero², David Huitink¹; ¹University of Arkansas, ²Nitride Global

ST-09 Transient Thermal Management, Controls, and Emerging Applications

DEL LAGO 3-4 Chairs: Pratik Bhansali (AMD) and Harsha Bojja (Google)

- 8:00 AM (#284) Estimating Omnimagnet Thermal Control Requirements for Space Cebris Remediation via Thermal and Electromagnetic Modeling Without Overheating;** Mason Pratt¹, Tim Ameen², Sameer Rao²; ¹Advanced Cooling Technologies, Inc., ²University of Utah
- 8:15 AM (#23) Digital Transformation of the Drying Process Using Spatial Thermography;** Hirotoishi Taira¹, Takeshi Yajima¹; ¹Tokyo Electric Power Company Holdings
- 8:30 AM (#56) Thermal Evaluation of Off-the-Shelf 3d-Stacked CPUs: Cache-on-Cpu vs. CPU-on-Cache;** Yeon Woo Jeong¹, Jae Yoon Lee¹, Sung Woo Chung¹; ¹Korea University
- 8:45 AM Sponsored Talk;** Carter Markey
(Sponsored)
- 9:00 AM (#73) Physics-Based Nonlinear State-Space Model for Real-Time Thermal Control in Solid State Drives;** Saeel Pai¹, Ran Ran¹, Li Chen¹, Chaolun Zheng², Ning Ye¹; ¹Sandisk Corporation, ²Western Digital Corporation

EF-09 Nanoscale and Transistor-Level Thermal Transport

SEGURA 5 Chairs: *Kidus Guye (University of Maryland at College Park) and Yiwen Song (Pennsylvania State University)*

- 8:00 AM** **Theoretical Investigation of Targeted Thermo-Electric Hot Spot Cooling in CPUs;** David Coenen¹, Herman Oprins¹; ¹*imec*
(#122)
- 8:15 AM** **Thermal Management Challenges and Strategies for GaN-Based Microinverters in Photovoltaic Systems;** Miriam Dixon¹, Ayooluwa Ajiboye¹, Hassan H. Chaudhry¹, Benjamin M. Shani¹, Amir Shooshtari¹, Alireza Khaligh¹, Michael Ohadi¹; ¹*University of Maryland at College Park*
(#166)
- 8:30 AM** **Thermal Conductivity and Phonon Properties of Ultra-Wide Bandgap Transition-Metal Nitride Ternary Alloys for Next-Generation Radio Frequency Devices;** Minsung An¹, Jonathan A. Malen¹, Alan McGaughey¹; ¹*Carnegie Mellon University*
(#232)
- 8:45 AM** **Impact of Alloy Grading on the Thermal Transport in AlN/Al_xGa_{1-x}N/GaN Heterostructures: Atomistic Simulation Using Machine Learned Interatomic Potentials;** Arnab Das¹, Hariharan Ramasubramanian¹, Jonathan A. Malen¹, Alan McGaughey¹; ¹*Carnegie Mellon University*
(#287)
- 9:00 AM** **Transistor Level, Geometry-Driven Thermal Management in FinFET and FDSOI Technology;** Lisa Tondelli¹, Bjorn Vermeersch¹, Luca Selmi², Herman Oprins¹; ¹*imec*, ²*Università degli studi di Modena e Reggio Emilia*
(#338)

MR-09 Solder Joints - II

SEGURA 6 Chairs: *Himel Barua (Oak Ridge National Laboratory) and David Huitink (University of Arkansas)*

- 8:00 AM** **Effect of Thermal Cycling on the Microstructure and Creep Response of Lead-Free BGA Packages;** Seiyefa A. Vincent¹, Mohammad Al Ahsan¹, Jeffrey Suhling¹, Pradeep Lall¹; ¹*Auburn University*
(#244)
- 8:15 AM** **Improved Finite Element Based Predictions of BGA Thermal Fatigue Life Using Evolving Solder Material Behavior;** Omma Sumaiya¹, Souvik Chakraborty¹, Golam Rakib Mazumder¹, Jeffrey Suhling¹, Pradeep Lall¹; ¹*Auburn University*
(#248)
- 8:30 AM** **Mechanical Properties Evolution in SAC-LTS Hybrid Solders Subjected to Aging;** Mahbub Alam Maruf¹, Souvik Chakraborty¹, Jeffrey Suhling¹, Pradeep Lall¹; ¹*Auburn University*
(#258)
- 8:45 AM** **The Influence of Bi and Sb Micro-Doping on the Tensile Properties of Sn-Ag-Cu Solder Alloys;** Sergio Bolanos¹, Waad Tarman¹, Abdallah H. Alakayleh¹, Saddam Daradkeh¹, Yanal Masarweh¹, Jeffrey Suhling¹, Sa'd Hamasha²; ¹*Auburn University*, ²*Binghamton University*
(#277)
- 9:00 AM** **Thermomechanical Reliability Evaluation of Solder Joints for MLCC Capacitors;** Himel Barua¹, Paul Paret², Shajjad Chowdhury¹, Burak Ozpineci¹, Sreekant Narumanchi²; ¹*Oak Ridge National Laboratory*, ²*National Laboratory of the Rockies*
(#342)

Day 3: Friday, May 29th 11:00 AM–12:30 PM

P-10 Cooling for AI and AI for Cooling

AMARANTE 2-3 Chairs: *Damena Agonafer (University of Maryland at College Park) and Remco van Erp (Corintis)*
 Panelists: *Ryan Enright (Seguente), Chirag Kharangate (Case Western Reserve University), Sung Ki Kim (Intel) and Michael Ohadi (University of Maryland at College Park)*

CT-10 Single-Phase Cold Plates - Experimental

DEL LAGO 1-2 Chairs: *Aakrati Jain (IBM) and Kaiying Jiang (Stanford University)*

- 11:00 AM (#78) Design and Experimental Characterization of Micro Pin-Array Cold Plates for Direct Single-Phase Liquid Cooling of High-Performance Chips;** Nicholas Gallo¹, Erfan Rasouli¹, Vinod Narayanan¹; ¹*University of California Davis*
- 11:15 AM (Sponsored) Sponsored Talk;** Rob Bajadek
- 11:30 AM (#315) External Single-Phase Liquid Cooling of Lithium-Ion Batteries;** Young Jin Lee¹, Hrushikesh Jadhav¹, Daniel Zhu¹, Jason Siegel¹, Greg Less¹, Solomon Adera¹; ¹*University of Michigan*
- 12:00 PM (#359) Cross-Rib Enhanced Heat Transfer and Near-Chip Cooling for 1600W Chip With 857 Mm²;** Chuan Chen¹, Jia o. Deng¹, Yeye o. Li¹, Rong o. Fu¹, Liqiang Cao¹, Qidong Wang¹, Wenzheng Jiang¹, Delong Qiu²; ¹*Institute of Microelectronics of The Chinese Academy of Sciences*, ²*Jiashan Fudan Institute*
- 12:15 PM (#403) Design and Characterization of Micro-Fluidic Cold Plate for Traction Power Modules;** Yu Chen¹, Kewei Xiao¹, Man Prakash Gupta¹, Michael Degner¹; ¹*Ford Motor Company*

DC-10 Hybrid and Novel Cooling Methods for Data Centers

DEL LAGO 3-4 Chairs: *Prasanna Jayaramu (The University of Texas at Arlington) and Anil (Neil) Yuksel (Ecolab)*

- 11:00 AM (#427) Thermohydraulic Modeling of Microchannel Cold Plates for Two-Phase Data Center Cooling;** Qingyang Wang¹, Trevor Whitaker¹, Akshith Narayanan¹, Serdar Ozguc¹, Jacob Moore¹, Richard Bonner¹; ¹*Accelsius*
- 11:15 AM (#391) Experimental Investigation of Passive Flow Regulators for Stabilizing Rack-Level Two-Phase D2C Cooling Systems;** Ali Heydari¹, Omar Al-Zu'bi², Yaman Manaserh¹, Ahmad Gharaibeh², Ala'a Al Tubeshat², Mehdi Mehrabikermani³, Bahgat Sammaki²; ¹*Nvidia Corporation*, ²*Binghamton University*, ³*Villanova University*
- 11:45 AM (Sponsored) Thermal Imaging of 3D Heterogeneously Integrated AI Packages to Enable Smarter Cooling Design;** Mo Shakouri
- 12:00 PM (#127) High-Efficiency Pumped Two-Phase Cooling Solution for IBM Z Mainframes: Design, Implementation & Single-Drawer Performance Results;** Felipe A. Valenzuela-Gaete¹, A. Cory VanDeventer¹, Charles Gary II¹, Milnes P. David¹; ¹*IBM*
- 12:15 PM (#63) Experimental Investigation of R1234ze(E) Condensation in Liquid-Cooled Brazed Plate Heat Exchangers for Pumped Two-Phase Data Center Cooling Applications;** Pranay P. Nagrani¹, Brian Werneke¹, Milnes P. David¹, Pritish Parida², Carol Caceres¹, Timothy Chainer¹; ¹*IBM*, ²*IBM Research*

EF-10 Thermal Characterization of Advanced Materials

SEGURA 5 Chairs: *Arad Azizi (Solstice Advanced Materials) and Shuye Zhang (Harbin Institute of Technology)*

- 11:00 AM** **Characterization of the Anisotropic Thermal Conductivity of AlN and GaN Thin Films;** (#74) Juan Pablo Murrieta Cortes¹, Husam Walwil¹, Jimy Encomendero², Seung Hoon Lee¹, Eungkyun Kim², Joan M. Redwing¹, Debdeep Jena², Huili Grace Xing², Sukwon Choi¹; ¹*Pennsylvania State University*, ²*Cornell University*
- 11:15 AM** **Thermal Conductivity of Engineered Polycrystalline Diamond Membranes;** (#159) Husam Walwil¹, Chenyu Wang², Xuanyu Zhou², Luke Suter³, Matthias Muehle³, Jung-Hun Seo², Sukwon Choi¹; ¹*Pennsylvania State University*, ²*University at Buffalo*, ³*Fraunhofer*
- 11:30 AM** **Reliability of the Encapsulated Phase Change Materials Under Thermal Cycling;** (#273) Muhammad Ghufuran¹, Logan I. Keehn¹, David Huitink¹; ¹*University of Arkansas*
- 11:45 AM** **Design and Thermal Performance Evaluation of a Thermal Capacitor for Passive Cooling of Electronic Devices;** (#335) Thieru Mahan Arjun Elangovan¹, Venu Prasad¹, Mirdul R.B¹, Deenathayalan P K¹, Rohit Rajesh¹, Udit Narayan Sai Pyla¹, Anusuya K¹; ¹*SRM Institute of Science and Technology*
- 12:00 PM** **Validation of Parameter-Free DFT-Landauer Methodology for Thermal Boundary Conductance in Van Der Waals Heterostructures;** (#371) Krithik Senthilkumar¹, Rayan Malik²; ¹*Illinois Mathematics and Science Academy*, ²*Illinois Math and Science Academy*
- 12:15 PM** **Self-Healing Liquid Metal Microchannels: Coupled VOF/CHT Modeling of Flow-Driven Recovery;** (#372) Krithik Senthilkumar¹, Rayan Malik²; ¹*Illinois Mathematics and Science Academy*, ²*Illinois Math and Science Academy*

ST-10 Two-Phase Cooling and Flow Control

SEGURA 6 Chairs: *Ghazal Mohsenian (Advantest) and Dhruvalkumar Shah (Cisco Systems)*

- 11:00 AM** **Characterization of Low GWP Refrigerants in Direct to Chip Two-Phase Cooling for High Heat Flux Applications;** (#174) Ali Heydari¹, Yousaf Shah², Alfonso Ortega², Yaman Manaserh¹; ¹*Nvidia Corporation*, ²*Villanova University*
- 11:15 AM** **Experimental Investigation of Spring-Loaded Flow Regulators for Managing Flow Distribution in Pumped Refrigerant Two-Phase Cooling Loops;** (#169) Ali Heydari¹, Mehdi Mehrabikermani², Yaman Manaserh¹, Omar Al-Zu'bi³, Alfonso Ortega²; ¹*Nvidia Corporation*, ²*Villanova University*, ³*Binghamton University*
- 11:30 AM** **Experimental and Analytical Investigation of Two-Phase Flow Boiling in Copper Gyroid Structures for Cold Plate Applications;** (#291) Bolape Alade¹, Alfonso Ortega¹, Ian Winfield², Gautam Gupta², Joseph Madril²; ¹*Villanova University*, ²*Fabric⁸ Labs*
- 11:45 AM** **Mitigation of Flow Boiling Instabilities via Active Flow Control;** (#238) Daksh Adhikari¹, Satish Kumar¹; ¹*Georgia Institute of Technology*
- 12:00 PM** **Towards 1 MW Data Center Racks: System-Level Modeling of a Membrane-Assisted Two-Phase Cooling Architecture;** (#272) Roshith Mittakolu¹, Ibaad Gandikota¹, Damena Agonafer¹, Francis P. McCluskey¹, Saeed Moghaddam²; ¹*University of Maryland at College Park*, ²*University of Florida*
- 12:15 PM** **Immersion and Shallow Pool Boiling of Novec 649 on Planar/Finned Copper Inverse Opal Structures;** (#137) Hongchi Liu¹, Daeyoung Kong², Kaiying Jiang¹, Heungdong Kwon³, Yujui Lin¹, Mehdi Asheghi¹, Kenneth Goodson¹; ¹*Stanford University*, ²*KoolMicro, Inc.*, ³*Kyung Hee University*

List of Reviewers

PAPER REVIEWERS

Thank you to all our paper reviewers, whose time and efforts ensure the high quality and technical merit of the papers published at ITherm 2026.

Abbasali Abouei Mehrizi	Souvik Chakraborty	Abantika Ghosh
Harshith Kumar Adepu	Darshan Chalise	Durga Ghosh
Kaustubh Adsul	Gokul Chandrasekaran	Muhammad Ghufuran
John Aguirre	Vishnuprasad Chandrasekaran	Biruk Teka Gidreta
Mudasir Ahmad	Shyy Chang	George Gogos
Faisal Ahmed	Xinyue Chang	Aman Goyal
Shoaib Ahmed	Rukmava Chatterjee	Shiraz Gulraiz
Olubunmi Akinola	Rajneesh Chaudhary	Kidus Guye
Tijesunimi Akintunde	Chuan Chen	Yong Han
Omar Al-Zu'bi	Tai-Yu Chen	Mobina Hatami Miri
Bolape Alade	Zhengwei Chen	Qi He
Abdallah Alakayleh	Jian Cheng	Farzaneh Hosseini
Cristina Amon	Paremesh Chintala	Chuqi Huang
Siddhant Aphale	Lochan Sai Reddy Chinthaparthi	Yanbo Huang
David Apigo	Youngsang Cho	Sushumna Iruvanti
Prashanth Avireddi	Mingeun Choi	Jebin Joshua Isaac Raj
Muhammad Awais	Padmanava Choudhury	Md Raisul Islam
Aigbe Awenlimobor	David Coenen	Md Shafiqul Islam
Veeresh Ayyagari	David Copeland	Shrenik Jadhav
Arad Azizi	Carlos Da Silva	Anup Jain
Ivneet Banga	Saddam Daradkeh	Prasanna Jayaramu
Abhijeet Banthiya	Siddharth Dasgupta	Kaiying Jiang
Carly Baracco	Douglas de Aquino Castro	Pallavi Jithendriyan
Kalind Baraya	Miriam Dixon	HangJin Jo
Krishna Baride	Kalyan Dornala	Chinmaya Joshi
Krishna Chandra Bavandla	Jianyu Du	Vedant Joshi
Judit Beagle	Ajul E	Sung-Jin Jung
Pratik Bhansali	Chetan harsha Edara	Jeremy Junghans
Aniket Bharamgonda	Ali Elgohary	Anusuya K
Deepika Bhatia	Georg Elsinger	Gargi Kailkhura
Dikshya Bhattarai	Meysam Emami	Daniel Karakitie
Sajjad Bigham	Ahmet Ata Ersoy	Sayan Karmakar
Sabina Bimali	Yaoyin Fan	Sushrut Karmarkar
Shreyas Bindiganavale	Yuehong Fan	Madhu Kasturi
Harsha Bojja	Kazuyoshi Fushinobu	Brian Kelly
Sergio Bolanos	Mohan Kumar Gajendran	Rehan Khalid
Manohar Bongarala	Viswanathan Ganesh	Daewhan Kim
Carol Caceres	Phil Geng	Jaechoon Kim
Ruander Cardenas	Reza Ghaffarian	
Ze CELLIER	Ahmad Gharaibeh	

Suhan Kim	Jean-Francois Morissette	Saket Rathi
Taeil Kim	Ram Munde	Bharath Ram Ravi
Mohammad Kokash	Selva Lakshman Murali	Bharath Viswanath Ravi
Daeyoung Kong	Muneeshwaran Murugan	Reza Reza Goharimehr
Piyush Kulkarni	Nooruldeen Mustafa	Kathryn Rivera
Ritwik Kulkarni	Pranay Nagrani	Daniel Rosenfeld
Saurabh Kulkarni	Mitul Naik	Rishav Roy
Shriram Kulkarni	Jinesh Narangaparambil	Prabudhya Roy Chowdhury
Vigneshwarram Kumaresan	Jayachandran Narayanan	Carin Ruiz
Foluso Ladeinde	Jacek Nazdrowicz	Hiroyuki Ryoson
Haeun Lee	Yuling Niu	Mrinmoy Saha
Heechul lee	Lucas Oelkers	Ridvan Sahan
Hao Li	Zane Olige	Prashant Saini
Xiangyu Li	Herman Oprins	Sangram Samal
Yueming Li	Todd Otanicar	Lior Samogora
Shuibao Liang	Zubin Padia	Saurabh Sarathe
Hung-Yun Lin	Saeel Pai	Bhaskarjyoti Sarma
Paixun Lin	Debabrata Pal	David Sarraf
Yujui Lin	Aathi Raja Ram Pandurangan	Md Golam Sarwar
Zheng Liu	Naimish Pandya	Pratayanch Sav
Melina Lofrano	Ying-Feng Pang	Mark Schultz
Jiajian Luo	Sarwesh Parbat	Dhruvalkumar Shah
John Maddox	Chirag Devendrakumar Parikh	Jimil Shah
Saroj Majakoti	Abhishek Pathak	Ujash Shah
Vivek Manepalli	Prashanth Pavithran	Javed Shaikh
Sujyesh Aanandh Manjunathan	Yong Pei	Michael Shanks
Vincent Manno	Thanh Hoang Phan	Deepak Sharma
Maurice Marongiu	Sylvain Pharand	Nishant Sharma
Mahbub Alam Maruf	Sunilkumar Pinnu	Yuqi Shi
Mohammad Al Bukhari Marzuki	Logan Pirnstill	Jaeho Shin
Golam Rakib Mazumder	Mason Pratt	Daniel Shoemaker
James Van Gilder	Nidheesh Puliyath	Maharshi Shukla
Mehdi Mehrabikermani	Farzad R.Talabazar	Vibin Shalom Simon
Luke Min	Unique Rahangdale	Abhishek Singh
Abel Misrak	Mostafa Rahimi Dizadji	Shambhavi Singh
Roshith Mittakolu	Md Emadur Rahman	Akiilessh Sivakumar
Risa Miyazawa	Mukund Rajamony	Braxton Smith
Farhan Mody	MD Abdul Goni Raju	Yiwen Song
Faizaan Mohammed	Alapati Ramakrishna	Qusai Soud
Ghazal Mohsenian	Sameer Rao	Karthekeyan Sridhar
Shanmukhi Sripada	Manikandan Sundararaj	Megha Tangri
Tyler Stamps	Ijaz Fazil Syed Ahmed Kabir	Ines-Noelly Tano
Lon Stevens	Hessam Taherian	Lisa Tondelli
Meiying Su	Suhas Tamvada	Devahdhanush V.S.

Beau Van Vaerenbergh
Nathan Van Velson
Eswaraiah Varrla
Aruna Veerasamy
Archana Venugopal
Steven Verhaverbeke
Naren Bharatwaj Vivekanandan
Palash Vyas
Husam Walwil
Keyu Wang
Qingyang Wang
Jie Wei
Xiaojin Wei
Trevor Whitaker
Ross Wilcoxon
Adam Wilson
Christopher Wise
Zekun Wu
Amy Xia
Vamsi Yaddanapudi
Cheng-Min Yang
Junbo Yang
Wenxi Yang
Yunchun Yang
Zhengda Yao
Onur Yenigun
Srinath Reddy Yerakondappagari
Pengcheng Yin
Ketan Yogi
Kenny Yu
Jun Zhang
Shuye Zhang
Xuewei Zhang
Yunli Zhang
Zechen Zhang
Beihan Zhao
Chaolun Zheng
David Zhou
Naarendharan Meenakshi Sundaram
Dayananda Swamy Kattimani Math
Mohammadamin Hajikhodaverdian



26th Intersociety Conference on Thermal and Thermomechanical Phenomena in Electronic Systems

Important Dates

Abstract Deadline:	Sept. 28, 2026
Notification of Acceptance:	Oct. 26, 2026
Draft Paper Submission:	Jan. 4, 2027
Reviews Returned:	Feb. 1, 2027
Final Paper Submission:	Mar. 1, 2027

Jun 1 – 4, 2027

Gaylord Rockies
Resort & Convention Center
Denver, CO, USA



Call for Abstracts

The IEEE ITherm Conference is the leading international conference for scientific and engineering exploration of thermal, thermomechanical, and emerging technology issues associated with electronic devices, packages, and systems. ITherm 2027 will be a physical conference held along with the 77th ECTC. Joint ITherm/ECTC registrations will be available at a significant discount. All abstracts are followed by full papers to be peer reviewed and published in the IEEE Xplore ITherm proceedings. Student first authors will have the opportunity to apply for ITherm travel grants, to participate in the Student Poster and Networking Session. ITherm 2027 will also feature keynotes by prominent speakers, vendor exhibits, panel discussions, invited technology talks, ECTC/ITherm joint networking events and short courses, and a student design competition. Original papers are solicited in the following areas:

Component-Level Thermal Management

- Advanced Packaging/HI Thermal Management
- Heat Pipes, Vapor Chambers and Thermosyphons
- Hotspot and Impingement Cooling
- Micro-gaps and Embedded Cooling
- RF and Power Electronics
- Single / Two-Phase Cold Plates and Heat Sinks
- Thermal Interface Materials and Heat Spreaders
- Thermal Management of Electric Machines

System-Level Thermal Management

- Air Cooling Techniques and Heat Exchangers
- Aerospace Thermal Management
- Automotive, Batteries and Thermal Storage
- Cryogenics and Refrigeration
- Immersion Cooling
- Liquid Cooling Solutions
- Transient Thermal Management

Mechanics and Reliability

- Accelerated Stress Testing and Modeling
- Advanced Packaging/HI Mechanics and Reliability
- Failure Mechanics, Fatigue and Damage Modeling
- Materials Characterization, Processing and Models
- Mechanics in Assembly and Manufacturing
- Measurement of Deformations, Strains and Stresses
- Shock, Drop and Vibrational Analysis
- Thermo-Mechanical Modeling and Simulation

Emerging Technologies and Fundamentals

- Additive Manufacturing and Topology Optimization
- Biomedical, Wearable, Flexible and Printed Electronics
- Boiling, Evaporation and Condensation
- Digital Twins
- DTCO, STCO, and Co-Design
- Measurement and Diagnostic Techniques
- Multi-scale, Multi-physics and Reduced Order Modeling
- Nanoscale and Transistor-Level Thermal Transport
- Next Generation Electronics
- Novel Materials and Fabrication Techniques
- Packaging and Interconnection Technologies
- Predictive Analytics, Machine Learning and AI
- Quantum Computing
- Thermoelectric and Peltier Devices

Data Centers

- Air Cooling Methods
- Carbon Emissions and Sustainability
- Economics and Scaling
- Hybrid and Novel Cooling Methods
- Liquid Cooling Methods
- Modeling, AI/ML Techniques, Control and Optimization
- Reliability and Failure Mitigation
- Performance Metrics, Standards and Regulatory Compliance

ITherm provides an opportunity for industrial and university participation in the form of financial support to ITherm 2026. All contributors will be given strong recognition both onsite and in the conference materials.



Program Inquiries:
Dr. Pritish Parida, Program Chair
program-chair@ieee-itherm.net
Prof. Sukwon Choi, Vice Program Chair
viceprogram-chair@ieee-itherm.net

CONFERENCE FLOOR MAPS

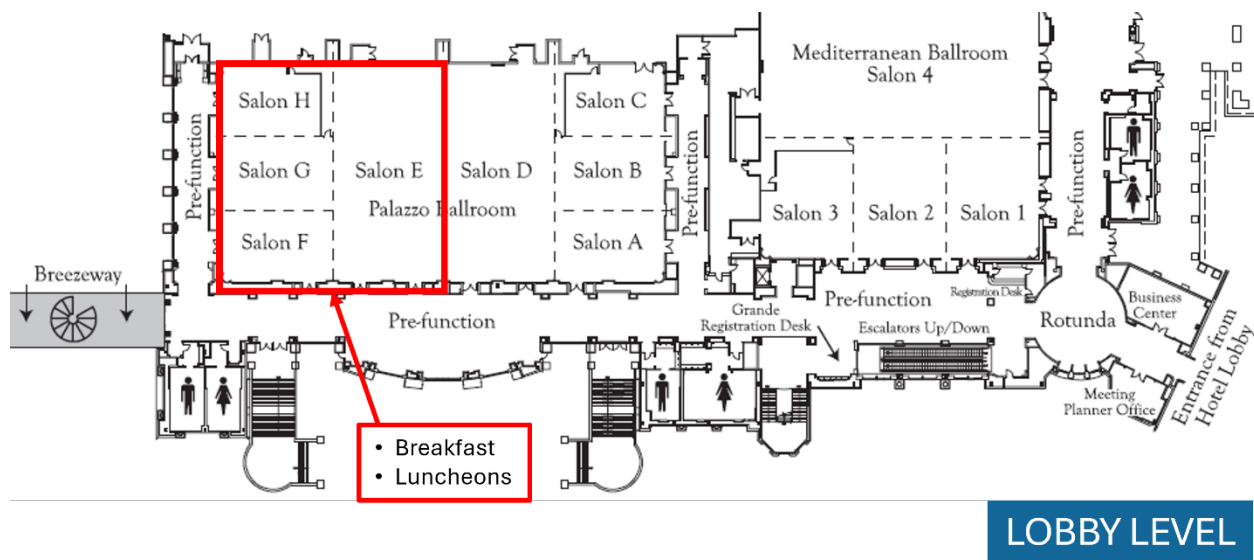
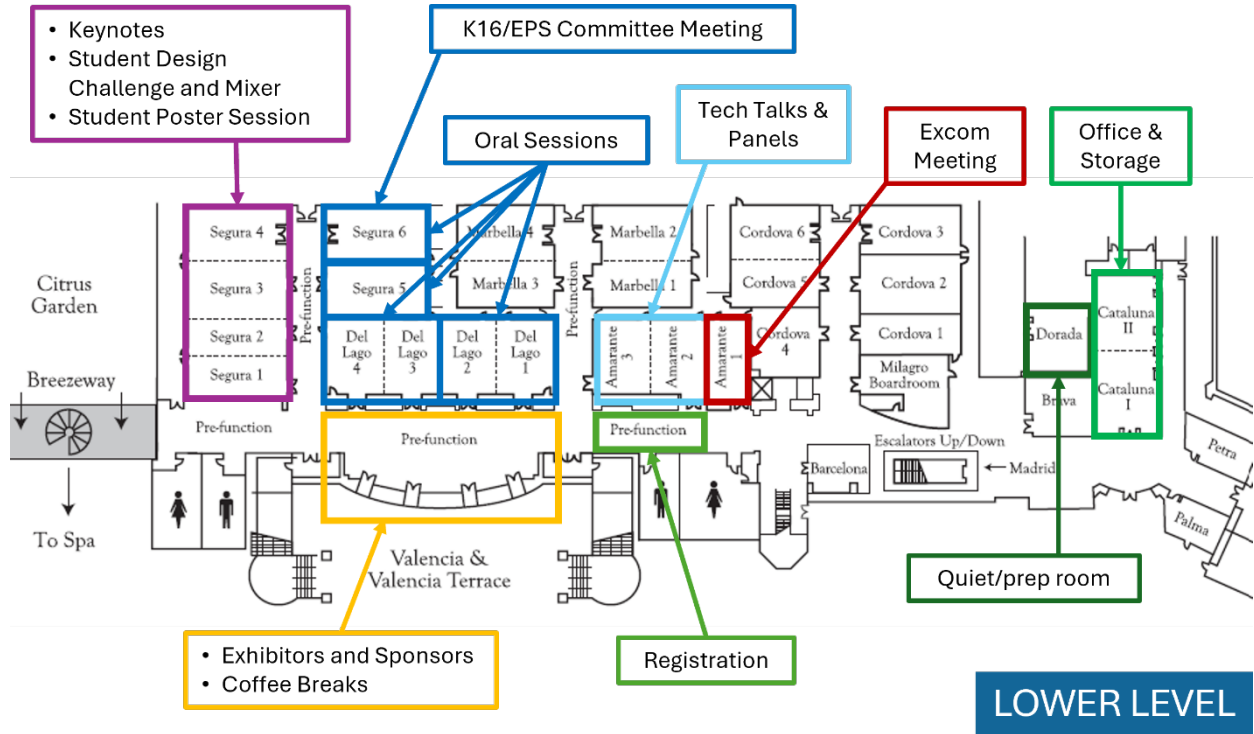

Conference Program Overview

Day-0: Tuesday, May 26, 2025

8:00 - 12:00	ECTC/ITherm Joint Professional Development Courses (PDC)	12:00 - 1:30	Luncheon for PDC Course Attendees	1:30 - 5:30	ECTC/ITherm Joint Professional Development Courses (PDC)	6:45 - 7:45	ECTC Young Professionals Networking Event
Professional Development Courses (PDC)		HIR Workshop (Open to All Attendees)		Registration & Exhibitor Setup (1:00 pm - 5:00 pm)		BREAK	
		CoreSite Tour (1:00-4:00)					

Day-1: Wednesday, May 27, 2026

7:00 - 8:00	Breakfast	8:00 - 9:15	CT-01A CT-01B ST-01 EF-01 TT-01	9:30-10:30	K-1 Keynote	11:00 - 12:30	CT-02 MR-02 DC-02 EF-02 P-02	12:30 - 2:00	Luncheon Richard Chu ITherm Award Presentation	2:00 - 3:30	CT-03 MR-03 ST-03B EF-03 TT-03	4:00 - 5:30	CT-04 MR-04 DC-04 EF-04 P-04	5:30 - 8:30	Student Design Challenge and Mixer
		BREAK		ITherm Sponsors & Exhibits		BREAK		ITherm Sponsors & Exhibits		BREAK		ASME K-16 & JEP Meetings (7:00 - 8:00)			
Art in Science Exhibition (7:00 am - 5:30 pm)															
Registration (6:30 am - 5:30 pm)															

Day-2: Thursday, May 28, 2026

7:00 - 8:00	Breakfast	8:00 - 9:15	CT-05A CT-05B ST-05 EF-05 TT-05	9:30-10:30	K-2 Keynote	11:00 - 12:30	CT-06 MR-06 DC-06 EF-06 P-06	12:30 - 2:00	Luncheon ITherm 25 th Anniversary Celebration & Retrospective	2:00 - 3:30	CT-07 MR-07 ST-07 EF-07 TT-07	4:00 - 5:30	CT-08 MR-08 DC-08 EF-08 P-08	5:30 - 7:00	Student Poster Networking Session and Reception	7:30-9:30	ITherm Organizers' Dinner
		BREAK		ITherm Sponsors & Exhibits		BREAK		ITherm Sponsors & Exhibits		BREAK		ITherm Sponsors & Exhibits		EXCom Meeting (7:00 - 7:30)		by Invitation	
Art in Science Exhibition (7:00 am - 5:30 pm)																	
Registration (7:00 am - 5:30 pm)																	

Day-3: Friday, May 29, 2026

7:00 - 8:00	Breakfast	8:00-9:15	CT-09 CT-09 ST-09 EF-09 TT-09	9:30-10:30	K-3 Keynote	11:00 - 12:30	CT-10 ST-10 DC-10 EF-10 P-10	12:30 - 2:00	Luncheon ITherm Awards & Organizer Recognitions	2:00 - 3:00	ITherm 2027 Planning Meeting (Open)	Exhibitor Breakdown				
		BREAK		ITherm Sponsors & Exhibits		BREAK		Exhibitor Breakdown								
Art in Science Exhibition (7:00 am - 2:00 pm)																
Registration (7:00 am - 12:00 pm)																

Legend:

CT- Component Thermal	Keynote
ST- System Thermal	Special Events
MR- Mech & Reliability	Meetings
EF- Emerging Tech.	PDCs
DC- Data Centers	Meals & Breaks
TT- Tech Talks	P- Panels

